

Installation Guide

X900168 3µm High Efficiency Diesel Fuel Filter Kit
With Priming Pump
Suitable for flow rates up to 220lph



Micron Rating: 3µm @ 99% efficient
Operating Temperature: -40°C to 121°C
Operating Pressure: 80 psi / 550 kPa / 5.5 bar

Kit contents:

- 1x P576614 M14 x 1.5 NPT Ports with Priming Pump
- 2x P581681 spin-on filter (one spare)
- 1x P569758 Drain Bowl
- 2x P506150 Straight Fitting
- 1x X220112 Water in Fuel Sensor Display Kit

Installation

We recommend that additional filtration should be considered as the primary filter and installed before the factory filter, which should be retained as originally fitted. It can also be installed as a final filter. Identify a suitable location to mount the filter assembly that:

- Allows access to replace the filter
- Allows access to the twist and drain valve, to drain separated water
- Provides visibility of the clear water collection bowl
- Is located away from heat sources

Necessary Mounting Dimensions:

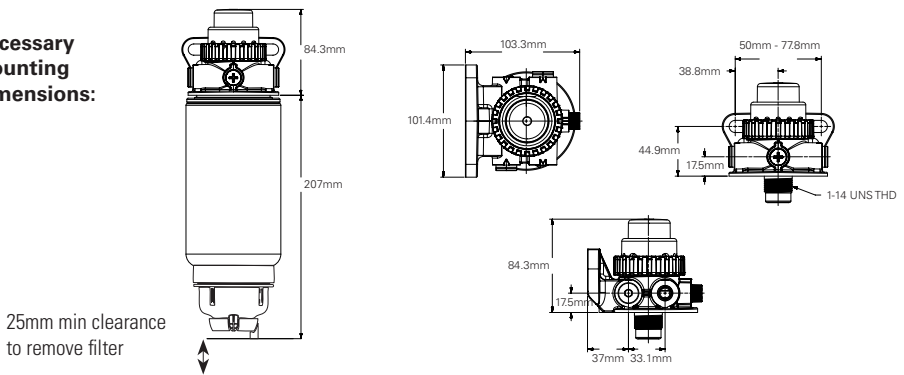

- The filter head should be securely fixed vertically to a bulkhead or mounting bracket using suitable screws or bolts.
- There is an inlet and outlet port on each side of the head assembly. Note, the flow direction is indicated on the head casting with an arrow. Install the threaded fuel line fittings into the head, as best suits your installation. Use the two blank plugs provided to block the unused inlet and outlet ports. Tighten all fittings firmly with a suitable tool. **Do not over tighten!** These fittings use an O-Ring seal, no additional sealant is required.
- Run the fuel supply line (from the fuel tank) and connect onto the fuel line fitting in the inlet port of the filter head. Secure with a suitable hose clamp.
- Run the fuel feed line (to the engine) and connect onto the fuel line fitting in the outlet port of the filter head. Secure with a suitable hose clamp.
- Check there are no tight bends or kinks in the fuel lines, and route them away from heat sources and sharp surfaces. Secure fuel lines to prevent excessive movement.

Installation Guide



1. Lubricate the threads.

Lubricate threads of filter head with clean oil or fuel

Failure to do this could result in thread galling.



2. Apply thin film of clean motor oil or fuel to gasket.

Lubricate seal(s) with clean oil.

Do not use grease or rubber grease.



3. Align threads. Spin filter until gasket contacts.

Spin the new filter on until the top of the gasket first contacts the sealing surface.



4. Hand tighten the filter.

Tighten per the guidance of the icons which appear on the filter element. Do not over-tighten. Ensure the drain valve is firm hand tight.



5. Install water collection bowl (if applicable)

Unscrew the Twist&Drain valve from the base of the filter. Screw the water collection bowl into the base of the filter and tension firm hand tight, then refit the Twist&Drain valve into the base of the bowl and tension firm hand tight.



6. Install WIF sensor

If the WIF sensor kit is to be used, replace the Twist&Drain valve with the one provided in the WIF sensor kit. This valve includes the sensor probe and electrical plug. Follow separate instructions provided for installation.



7. Prime fuel system per manufacturer

The air bleed valve on the top of the head is only used for pressurised fuel systems to allow

excess air out of the system. It should remain closed for vacuum fuel systems.



8. Start engine and check for leaks

Starting may take longer than normal for the first start.



9. Stop engine

Stop engine and recheck for leaks



10. Drain water daily

1/4 twist of the Twist&Drain valve. Once any water has been drained, re-tighten the valve until firm hand tight. A tube may be pushed over the drain spigot to aid collection of drained fluid.

Servicing Guide



1

Disconnect WIF sensor if present and reconnect after servicing



5

Apply thin film of clean motor oil to gasket



9

Prime fuel system per manufacturer



2

Unscrew and remove old filter and gasket



6

Align threads; spin filter on until gasket contact



10

Start engine and check for leaks



3

Wipe filter head with clean cloth



7

Follow icons on filter to tighten



11

Drain water daily



4

Fill with fuel on the dirty side per engine manufacturer recommendations



8

Replace water collection bowl gasket if applicable

This manual is the property of the owner. Donaldson Company reserves the right to change design and specifications without prior notice. Do not make any system modifications or adjustments that would alter the original design. Modifications may result in denial of warranty coverage. Consult your Donaldson dealer if you have questions regarding the assembly, operation, maintenance or warranty. Illustrations are for reference only as actual product may vary.