



CHROMEND SUPPLY CO. – TRUCK CATALOGUE 2007

Mild Steel Mandrel Bends 30° (Standard Radius)

SB15030	Mild Steel Mandrel Bend - 1½" x 30°		
SB15830	Mild Steel Mandrel Bend - 1⅝" x 30°		
SB17530	Mild Steel Mandrel Bend - 1¾" x 30°		
SB17830	Mild Steel Mandrel Bend - 1⅞" x 30°		
SB20030	Mild Steel Mandrel Bend - 2" x 30°		
SB22530	Mild Steel Mandrel Bend - 2¼" x 30°		
SB25030	Mild Steel Mandrel Bend - 2½" x 30°		
SB30030	Mild Steel Mandrel Bend - 3" x 30° - Also SB30010 (3" x 10°) & SB30020° (3" x 20°)		
SB35030	Mild Steel Mandrel Bend - 3½" x 30°		
SB40030	Mild Steel Mandrel Bend - 4" x 30°		
SB50030	Mild Steel Mandrel Bend - 5" x 30°		

Mild Steel Mandrel Bends 45° (Standard Radius)

SB10045	Mild Steel Mandrel Bend - 1" x 45°		
SB11845	Mild Steel Mandrel Bend - 1⅛" x 45°		
SB12545	Mild Steel Mandrel Bend - 1¼" x 45°		
SB13845	Mild Steel Mandrel Bend - 1⅜" x 45°		
SB15045	Mild Steel Mandrel Bend - 1½" x 45°		
SB15845	Mild Steel Mandrel Bend - 1⅝" x 45°		
SB17545	Mild Steel Mandrel Bend - 1¾" x 45°		
SB17845	Mild Steel Mandrel Bend - 1⅞" x 45°		
SB20045	Mild Steel Mandrel Bend - 2" x 45°		
SB21845	Mild Steel Mandrel Bend - 2⅛" x 45°		
SB22545	Mild Steel Mandrel Bend - 2¼" x 45°		
SB25045	Mild Steel Mandrel Bend - 2½" x 45°		
SB27545	Mild Steel Mandrel Bend - 2¾" x 45°		
SB30045	Mild Steel Mandrel Bend - 3" x 45°		
SB35045	Mild Steel Mandrel Bend - 3½" x 45°		
SB40045	Mild Steel Mandrel Bend - 4" x 45°		
SB45045	Mild Steel Mandrel Bend - 4½" x 45°		
SB50045	Mild Steel Mandrel Bend - 5" x 45°		
SB60045	Mild Steel Mandrel Bend - 6" x 45°		
SB70045	Mild Steel Mandrel Bend - 7" x 45° (Precision cut from a donut - 2mm wall - no leg - tight radius)		
SB80045	Mild Steel Mandrel Bend - 8" x 45° (Precision cut from a donut - 2mm wall - no leg - tight radius)		
SB100045	Mild Steel Mandrel Bend - 10" x 45° (Precision cut from a donut - 2mm wall - no leg - tight radius)		

Mild Steel Mandrel Bends 60° (Standard Radius)

SB15060	Mild Steel Mandrel Bend - 1½" x 60°	
SB15860	Mild Steel Mandrel Bend - 1⅝" x 60°	
SB17560	Mild Steel Mandrel Bend - 1¾" x 60°	
SB17860	Mild Steel Mandrel Bend - 1⅞" x 60°	

CHROMEND SUPPLY CO. – TRUCK CATALOGUE 2007

Mild Steel Mandrel Bends 60° (Standard Radius)

SB20060	Mild Steel Mandrel Bend - 2" x 60°		
SB22560	Mild Steel Mandrel Bend - 2¼" x 60°		
SB25060	Mild Steel Mandrel Bend - 2½" x 60°		
SB30060	Mild Steel Mandrel Bend - 3" x 60° - Also SB30075 (3" x 75°)		
SB35060	Mild Steel Mandrel Bend - 3½" x 60°		
SB40060	Mild Steel Mandrel Bend - 4" x 60°		
SB50060	Mild Steel Mandrel Bend - 5" x 60°		

Mild Steel Mandrel Bends 90° (Standard Radius)

SB10090	Mild Steel Mandrel Bend - 1" x 90°		
SB11890	Mild Steel Mandrel Bend - 1⅛" x 90°		
SB12590	Mild Steel Mandrel Bend - 1¼" x 90°		
SB13890	Mild Steel Mandrel Bend - 1⅜" x 90°		
SB15090	Mild Steel Mandrel Bend - 1½" x 90°		
SB15890	Mild Steel Mandrel Bend - 1⅝" x 90°		
SB17590	Mild Steel Mandrel Bend - 1¾" x 90°		
SB17890	Mild Steel Mandrel Bend - 1⅞" x 90°		
SB20090	Mild Steel Mandrel Bend - 2" x 90°		
SB21890	Mild Steel Mandrel Bend - 2⅛" x 90°		
SB22590	Mild Steel Mandrel Bend - 2¼" x 90°		
SB25090	Mild Steel Mandrel Bend - 2½" x 90°		
SB27590	Mild Steel Mandrel Bend - 2¾" x 90°		
SB30090	Mild Steel Mandrel Bend - 3" x 90°		
SB35090	Mild Steel Mandrel Bend - 3½" x 90°		
SB40090	Mild Steel Mandrel Bend - 4" x 90°		
SB45090	Mild Steel Mandrel Bend - 4½" x 90°		
SB50090	Mild Steel Mandrel Bend - 5" x 90°		
SB60090	Mild Steel Mandrel Bend - 6" x 90°		
SB70090	Mild Steel Mandrel Bend - 7" x 90° (Precision cut from a donut - 2mm wall - no leg)		
SB80090	Mild Steel Mandrel Bend - 8" x 90° (Precision cut from a donut - 2mm wall - no leg)		
SB100090	Mild Steel Mandrel Bend - 10" x 90° (Precision cut from a donut - 2mm wall - no leg)		

Mild Steel Mandrel Bends 180° (Standard Radius)

SB100180	Mild Steel Mandrel Bend - 1" x 180°	
SB118180	Mild Steel Mandrel Bend - 1⅛" x 180°	
SB125180	Mild Steel Mandrel Bend - 1¼" x 180°	
SB138180	Mild Steel Mandrel Bend - 1⅜" x 180°	
SB150180	Mild Steel Mandrel Bend - 1½" x 180°	
SB158180	Mild Steel Mandrel Bend - 1⅝" x 180°	
SB175180	Mild Steel Mandrel Bend - 1¾" x 180°	
SB178180	Mild Steel Mandrel Bend - 1⅞" x 180°	

CHROMEND SUPPLY CO. – TRUCK CATALOGUE 2007

Mild Steel Mandrel Bends 180° (Standard Radius)

SB200180	Mild Steel Mandrel Bend - 2" x 180°		
SB218180	Mild Steel Mandrel Bend - 2 1/8" x 180°		
SB225180	Mild Steel Mandrel Bend - 2 1/4" x 180°		
SB250180	Mild Steel Mandrel Bend - 2 1/2" x 180°		
SB275180	Mild Steel Mandrel Bend - 2 3/4" x 180°		
SB300180	Mild Steel Mandrel Bend - 3" x 180°		
SB350180	Mild Steel Mandrel Bend - 3 1/2" x 180°		
SB400180	Mild Steel Mandrel Bend - 4" x 180°		

Mild Steel Heavy Duty Steam Pipe Bends 45° (3.2mm Wall) (All sizes are ID) - Tube Pages 34 & 35

HDB12545	Mild Steel Heavy Duty Steam Pipe Bend - 1 1/4" x 45° (35mm inside diameter)	
HDB15045	Mild Steel Heavy Duty Steam Pipe Bend - 1 1/2" x 45° (41mm inside diameter)	
HDB20045	Mild Steel Heavy Duty Steam Pipe Bend - 2" x 45° (52mm inside diameter)	
HDB25045	Mild Steel Heavy Duty Steam Pipe Bend - 2 1/2" x 45° (63mm inside diameter)	
HDB30045	Mild Steel Heavy Duty Steam Pipe Bend - 3" x 45° (77mm inside diameter)	
HDB40045	Mild Steel Heavy Duty Steam Pipe Bend - 4" x 45° (103mm inside diameter)	

Mild Steel Heavy Duty Steam Pipe Bends 90° (3.2mm Wall) (All sizes are ID) - Tube Pages 34 & 35

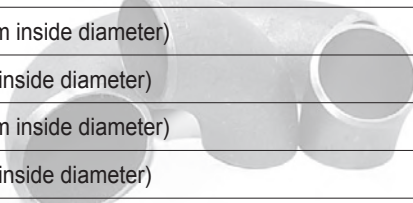
HDB12590	Mild Steel Heavy Duty Steam Pipe Bend - 1 1/4" x 90° (35mm inside diameter)		
HDB15090	Mild Steel Heavy Duty Steam Pipe Bend - 1 1/2" x 90° (41mm inside diameter)		
HDB20090	Mild Steel Heavy Duty Steam Pipe Bend - 2" x 90° (52mm inside diameter)		
HDB25090	Mild Steel Heavy Duty Steam Pipe Bend - 2 1/2" x 90° (63mm inside diameter)		
HDB30090	Mild Steel Heavy Duty Steam Pipe Bend - 3" x 90° (77mm inside diameter)		
HDB40090	Mild Steel Heavy Duty Steam Pipe Bend - 4" x 90° (103mm inside diameter)		

Mild Steel Heavy Duty Steam Pipe Bends 180° (3.2mm Wall) (All sizes are ID) - Tube Pages 34 & 35

HDB125180	Mild Steel Heavy Duty Steam Pipe Bend - 1 1/4" x 180° (35mm inside diameter)	
HDB150180	Mild Steel Heavy Duty Steam Pipe Bend - 1 1/2" x 180° (41mm inside diameter)	
HDB200180	Mild Steel Heavy Duty Steam Pipe Bend - 2" x 180° (52mm inside diameter)	
HDB250180	Mild Steel Heavy Duty Steam Pipe Bend - 2 1/2" x 180° (63mm inside diameter)	
HDB300180	Mild Steel Heavy Duty Steam Pipe Bend - 3" x 180° (77mm inside diameter)	
HDB400180	Mild Steel Heavy Duty Steam Pipe Bend - 4" x 180° (103mm inside diameter)	



Aluminised Mandrel Bends 45° (Standard Radius)

AB25045	Aluminised Mandrel Bend - 2 1/2" x 45°	
AB30045	Aluminised Mandrel Bend - 3" x 45°	
AB35045	Aluminised Mandrel Bend - 3 1/2" x 45°	
AB40045	Aluminised Mandrel Bend - 4" x 45°	
AB45045	Aluminised Mandrel Bend - 4 1/2" x 45°	
AB50045	Aluminised Mandrel Bend - 5" x 45°	
AB60045	Aluminised Mandrel Bend - 6" x 45°	

CHROMEND SUPPLY CO. – TRUCK CATALOGUE 2007

Aluminised Mandrel Bends 90° (Standard Radius)		
AB25090	Aluminised Mandrel Bend - 2½" x 90°	
AB30090	Aluminised Mandrel Bend - 3" x 90°	
AB35090	Aluminised Mandrel Bend - 3½" x 90°	
AB40090	Aluminised Mandrel Bend - 4" x 90°	
AB45090	Aluminised Mandrel Bend - 4½" x 90°	
AB50090	Aluminised Mandrel Bend - 5" x 90° (Leg Length - 300mm x 300mm)	
AB60090	Aluminised Mandrel Bend - 6" x 90°	
Aluminised Mandrel Bends 180°		
AB350180	Aluminised Mandrel Bend - 3½" x 180°	
AB400180	Aluminised Mandrel Bend - 4" x 180°	
Aluminised Mandrel Bends - Long Leg - 45° (Standard Radius)		
AB30045LL	Aluminised Mandrel Bend - 3" x 45° Long Leg (Leg Length - 295mm x 550mm)	
AB35045LL	Aluminised Mandrel Bend - 3½" x 45° Long Leg (Leg Length - 300mm x 550mm)	
AB40045LL	Aluminised Mandrel Bend - 4" x 45° Long Leg (Leg Length - 280mm x 565mm)	
AB45045LL	Aluminised Mandrel Bend - 4½" x 45° Long Leg (Leg Length - 300mm x 550mm)	
AB50045LL	Aluminised Mandrel Bend - 5" x 45° Long Leg (Leg Length - 320mm x 530mm)	
Aluminised Mandrel Bends - Long Leg - 90° (Standard Radius)		
AB30090LL	Aluminised Mandrel Bend - 3" x 90° Long Leg (Leg Length - 295mm x 600mm)	
AB35090LL	Aluminised Mandrel Bend - 3½" x 90° Long Leg (Leg Length - 300mm x 600mm)	
AB40090LL	Aluminised Mandrel Bend - 4" x 90° Long Leg (Leg Length - 350mm x 570mm)	
AB45090LL	Aluminised Mandrel Bend - 4½" x 90° Long Leg (Leg Length - 388mm x 543mm)	
AB50090LL	Aluminised Mandrel Bend - 5" x 90° Long Leg (Leg Length - 480mm x 600mm)	
Aluminium Mandrel Bends 25° - Lightweight Air (Standard Radius)		
ALB20025	Aluminium Mandrel Bend - 2" x 25° Lightweight Air	
ALB22525	Aluminium Mandrel Bend - 2¼" x 25° Lightweight Air	
ALB25025	Aluminium Mandrel Bend - 2½" x 25° Lightweight Air	
ALB30025	Aluminium Mandrel Bend - 3" x 25° Lightweight Air	
Aluminium Mandrel Bends 45° - Lightweight Air		
ALB20045	Aluminium Mandrel Bend - 2" x 45° Lightweight Air	
ALB22545	Aluminium Mandrel Bend - 2¼" x 45° Lightweight Air	
ALB25045	Aluminium Mandrel Bend - 2½" x 45° Lightweight Air	
ALB30045	Aluminium Mandrel Bend - 3" x 45° Lightweight Air	
Aluminium Mandrel Bends 75° - Lightweight Air		
ALB20075	Aluminium Mandrel Bend - 2" x 75° Lightweight Air	
ALB22575	Aluminium Mandrel Bend - 2¼" x 75° Lightweight Air	
ALB25075	Aluminium Mandrel Bend - 2½" x 75° Lightweight Air	
ALB30075	Aluminium Mandrel Bend - 3" x 75° Lightweight Air	
* Leg lengths are measured from the centre of bend to end.		
* Remember all leg lengths quoted are approx. only. Special leg lengths are available on some sizes. Min. quantities do apply.		

CHROMEND SUPPLY CO. – TRUCK CATALOGUE 2007

Aluminium Mandrel Bends 90° - Lightweight Air		
ALB20090	Aluminium Mandrel Bend - 2" x 90° Lightweight Air	
ALB22590	Aluminium Mandrel Bend - 2¼" x 90° Lightweight Air	
ALB25090	Aluminium Mandrel Bend - 2½" x 90° Lightweight Air	
ALB30090	Aluminium Mandrel Bend - 3" x 90° Lightweight Air	
Aluminium Mandrel Bends 125° - Lightweight Air		
ALB200125	Aluminium Mandrel Bend - 2" x 125° Lightweight Air	
ALB225125	Aluminium Mandrel Bend - 2¼" x 125° Lightweight Air	
ALB250125	Aluminium Mandrel Bend - 2½" x 125° Lightweight Air	
ALB300125	Aluminium Mandrel Bend - 3" x 125° Lightweight Air	
Aluminium Mandrel Bends 180° - Lightweight Air		
ALB200180	Aluminium Mandrel Bend - 2" x 180° Lightweight Air	
ALB225180	Aluminium Mandrel Bend - 2¼" x 180° Lightweight Air	
ALB250180	Aluminium Mandrel Bend - 2½" x 180° Lightweight Air	
ALB300180	Aluminium Mandrel Bend - 3" x 180° Lightweight Air	
Aluminised Tight Radius Mandrel Bends 90°		
SRA30090	Aluminised Tight Radius Mandrel Bend - 3" x 90°	
SRA35090	Aluminised Tight Radius Mandrel Bend - 3½" x 90°	
SRA40090	Aluminised Tight Radius Mandrel Bend - 4" x 90°	
SRA50090*	* 14 gauge wall - Aluminised Tight Radius Mandrel Bend - 5" x 90°	
SRA60090	Aluminised Tight Radius Mandrel Bend - 6" x 90°	
Mild Steel Tight Radius Mandrel Bends 90°		
TRSB35090	Mild Steel Tight Radius Mandrel Bend - 3½" x 90°	
TRSB40090	Mild Steel Tight Radius Mandrel Bend - 4" x 90°	
TRSB50090	Mild Steel Tight Radius Mandrel Bend - 5" x 90°	
TRSB60090	Mild Steel Tight Radius Mandrel Bend - 6" x 90° (Cut from a donut - no leg)	
TRSB70090	Mild Steel Tight Radius Mandrel Bend - 7" x 90° (Cut from a donut - no leg)	
TRSB80090	Mild Steel Tight Radius Mandrel Bend - 8" x 90° (Cut from a donut - no leg)	
Stainless Steel Mandrel Bends 45° (Grade 304) (Standard Radius)		
SSB10045-304	Stainless Steel Mandrel Bend - 1" x 45°	
SSB12545-304	Stainless Steel Mandrel Bend - 1¼" x 45°	
SSB15045-304	Stainless Steel Mandrel Bend - 1½" x 45°	
SSB15845-304	Stainless Steel Mandrel Bend - 1⅝" x 45°	
SSB17545-304	Stainless Steel Mandrel Bend - 1¾" x 45°	
SSB17845-304	Stainless Steel Mandrel Bend - 1⅞" x 45°	
SSB20045-304	Stainless Steel Mandrel Bend - 2" x 45°	
SSB22545-304	Stainless Steel Mandrel Bend - 2¼" x 45°	
SSB25045-304	Stainless Steel Mandrel Bend - 2½" x 45°	
SSB27545-304	Stainless Steel Mandrel Bend - 2¾" x 45°	
SSB30045-304	Stainless Steel Mandrel Bend - 3" x 45°	

CHROMEND SUPPLY CO. – TRUCK CATALOGUE 2007

Stainless Steel Mandrel Bends 45° (Grade 304) (Standard Radius)		
SSB35045-304	Stainless Steel Mandrel Bend - 3½" x 45°	
SSB40045-304	Stainless Steel Mandrel Bend - 4" x 45°	
SSB50045-304	Stainless Steel Mandrel Bend - 5" x 45°	
SSB60045-304	Stainless Steel Mandrel Bend - 6" x 45°	
Stainless Steel Mandrel Bends 90° (Grade 304) (Standard Radius)		
SSB10090-304	Stainless Steel Mandrel Bend - 1" x 90°	
SSB12590-304	Stainless Steel Mandrel Bend - 1¼" x 90°	
SSB15090-304	Stainless Steel Mandrel Bend - 1½" x 90°	
SSB15890-304	Stainless Steel Mandrel Bend - 1⅝" x 90°	
SSB17590-304	Stainless Steel Mandrel Bend - 1¾" x 90°	
SSB17890-304	Stainless Steel Mandrel Bend - 1⅞" x 90°	
SSB20090-304	Stainless Steel Mandrel Bend - 2" x 90°	
SSB22590-304	Stainless Steel Mandrel Bend - 2¼" x 90°	
SSB25090-304	Stainless Steel Mandrel Bend - 2½" x 90°	
SSB27590-304	Stainless Steel Mandrel Bend - 2¾" x 90°	
SSB30090-304	Stainless Steel Mandrel Bend - 3" x 90°	
SSB35090-304	Stainless Steel Mandrel Bend - 3½" x 90°	
SSB40090-304	Stainless Steel Mandrel Bend - 4" x 90°	
SSB50090-304	Stainless Steel Mandrel Bend - 5" x 90°	
SSB60090-304	Stainless Steel Mandrel Bend - 6" x 90°	
Stainless Steel Mandrel Bends 45° (Grade 316) (Standard Radius)		
SSB10045-316	Stainless Steel Mandrel Bend - 1" x 45°	
SSB12545-316	Stainless Steel Mandrel Bend - 1¼" x 45°	
SSB15045-316	Stainless Steel Mandrel Bend - 1½" x 45°	
SSB17545-316	Stainless Steel Mandrel Bend - 1¾" x 45°	
SSB20045-316	Stainless Steel Mandrel Bend - 2" x 45°	
SSB25045-316	Stainless Steel Mandrel Bend - 2½" x 45°	
SSB30045-316	Stainless Steel Mandrel Bend - 3" x 45°	
SSB35045-316	Stainless Steel Mandrel Bend - 3½" x 45°	
SSB40045-316	Stainless Steel Mandrel Bend - 4" x 45°	
SSB50045-316	Stainless Steel Mandrel Bend - 5" x 45°	
SSB60045-316	Stainless Steel Mandrel Bend - 6" x 45°	
Stainless Steel Mandrel Bends 90° (Grade 316) (Standard Radius)		
SSB10090-316	Stainless Steel Mandrel Bend - 1" x 90°	
SSB12590-316	Stainless Steel Mandrel Bend - 1¼" x 90°	
SSB15090-316	Stainless Steel Mandrel Bend - 1½" x 90°	
SSB17590-316	Stainless Steel Mandrel Bend - 1¾" x 90°	
SSB20090-316	Stainless Steel Mandrel Bend - 2" x 90°	
SSB25090-316	Stainless Steel Mandrel Bend - 2½" x 90°	

CHROMEND SUPPLY CO. – TRUCK CATALOGUE 2007

Stainless Steel Mandrel Bends 90° (Grade 316)		
SSB30090-316	Stainless Steel Mandrel Bend - 3" x 90°	
SSB35090-316	Stainless Steel Mandrel Bend - 3½" x 90°	
SSB40090-316	Stainless Steel Mandrel Bend - 4" x 90°	
SSB50090-316	Stainless Steel Mandrel Bend - 5" x 90°	
SSB60090-316	Stainless Steel Mandrel Bend - 6" x 90°	
Stainless Steel Mandrel Bends 180° (Grade 316)		
SSB100180-316	Stainless Steel Mandrel Bend - 1" x 180°	
SSB125180-316	Stainless Steel Mandrel Bend - 1¼" x 180°	
SSB150180-316	Stainless Steel Mandrel Bend - 1½" x 180°	
SSB200180-316	Stainless Steel Mandrel Bend - 2" x 180°	
SSB250180-316	Stainless Steel Mandrel Bend - 2½" x 180°	
SSB300180-316	Stainless Steel Mandrel Bend - 3" x 180°	
SSB400180-316	Stainless Steel Mandrel Bend - 4" x 180°	
Stainless Steel Mandrel Bends 180° (Grade 304)		
SSB125180-304	Stainless Steel Mandrel Bend - 1¼" x 180°	
SSB150180-304	Stainless Steel Mandrel Bend - 1½" x 180°	
SSB158180-304	Stainless Steel Mandrel Bend - 1⅝" x 180°	
SSB175180-304	Stainless Steel Mandrel Bend - 1¾" x 180°	
SSB178180-304	Stainless Steel Mandrel Bend - 1⅞" x 180°	
SSB200180-304	Stainless Steel Mandrel Bend - 2" x 180°	
SSB225180-304	Stainless Steel Mandrel Bend - 2¼" x 180°	
SSB250180-304	Stainless Steel Mandrel Bend - 2½" x 180°	
SSB300180-304	Stainless Steel Mandrel Bend - 3" x 180°	
SSB400180-304	Stainless Steel Mandrel Bend - 4" x 180°	
Chrome Plated Mandrel Steel Bends - 45°		
Standard Radius = 1.5 x diameter - 45° - plain ends		
CPB07645	Chrome Bend - 3" x 45°	
CPB08945	Chrome Bend - 3½" x 45°	
CPB10245	Chrome Bend - 4" x 45°	
CPB12745	Chrome Bend - 5" x 45°	
CPB12745L	Chrome Bend - 5" x 45° - Long Leg	
CPB15245	Chrome Bend - 6" x 45°	
Standard Radius = 1.5 x diameter - 45° - expanded & notched		
CPB07645X	Chrome Bend - 3" x 45° - Expanded & Notched	
CPB10245X	Chrome Bend - 4" x 45° - Expanded & Notched	
CPB10245LX	Chrome Bend - 4" x 45° - Expanded & Notched - Long Leg	
CPB12745X	Chrome Bend - 5" x 45° - Expanded & Notched	
CPB12745LX	Chrome Bend - 5" x 45° - Expanded & Notched - Long Leg	
CPB15245X	Chrome Bend - 6" x 45° - Expanded & Notched	



CHROMEND SUPPLY CO. – TRUCK CATALOGUE 2007

Chrome Plated Mandrel Steel Bends - 90°		
Standard Radius = 1.5 x diameter - 90° - plain ends		
CPB07690	Chrome Bend - 3" x 90°	
CPB08990	Chrome Bend - 3½" x 90°	
CPB10290	Chrome Bend - 4" x 90°	
CPB10290L	Chrome Bend - 4" x 90° - Long Leg	
CPB11490	Chrome Bend - 4½" x 90°	
CPB12790	Chrome Bend - 5" x 90°	
CPB12790L	Chrome Bend - 5" x 90° - Long Leg	
CPB15290	Chrome Bend - 6" x 90°	
Standard Radius = 1.5 x diameter - 90° - expanded & notched		
CPB06390X	Chrome Bend - 2½" x 90° - Expanded & Notched	
CPB07690X	Chrome Bend - 3" x 90° - Expanded & Notched	
CPB08990X	Chrome Bend - 3½" x 90° - Expanded & Notched	
CPB10290X	Chrome Bend - 4" x 90° - Expanded & Notched	
CPB10290LX	Chrome Bend - 4" x 90° - Expanded & Notched - Long Leg	
CPB12790X	Chrome Bend - 5" x 90° - Expanded & Notched	
CPB12790LX	Chrome Bend - 5" x 90° - Expanded & Notched	
CPB1279LXS	Chrome Bend - 5" x 90° - Expanded & Notched on Short Leg - Long Leg Length	
CPB15290X	Chrome Bend - 6" x 90° - Expanded & Notched	
90° Tight Radius = 1 x diameter		
CPB10290TR	Chrome Bend - 4" x 90° - Tight Radius	
CPB12790TR	Chrome Bend - 5" x 90° - Tight Radius - One Short Leg / One Long Leg	
CPB12790TRL	Chrome Bend - 5" x 90° - Tight Radius - Long Leg - Both Legs	
90° Tight Radius = 1 x diameter - expanded & notched		
CPB12790TRLX	Chrome Bend - 5" x 90° - Tight Radius - Long Leg - Expanded & Notched	
CPB12790TRXS	Chrome Bend - 5" x 90° - Tight Radius - Short Leg - Expanded & Notched	
Chrome Y Pipe		
JY500C	Y Pipe 5" OD outlets x 5" OD inlet	
Mild Steel Lipped Flange 22° (Plain)		
SLF2000	Mild Steel Lipped Flange - 2" x 22°	
SLF2250	Mild Steel Lipped Flange - 2¼" x 22°	
SLF2500	Mild Steel Lipped Flange - 2½" x 22°	
SLF2750	Mild Steel Lipped Flange - 2¾" x 22°	
SLF3000	Mild Steel Lipped Flange - 3" x 22°	
SLF3500	Mild Steel Lipped Flange - 3½" x 22°	
SLF4000	Mild Steel Lipped Flange - 4" x 22°	
SLF4500	Mild Steel Lipped Flange - 4½" x 22°	
SLF5000	Mild Steel Lipped Flange - 5" x 22°	
SLF6000	Mild Steel Lipped Flange - 6" x 22°	



CHROMEND SUPPLY CO. – TRUCK CATALOGUE 2007

Aluminised Lipped Flange 22° (Plain)		
SLF2000A	Aluminised Lipped Flange - 2" x 22°	
SLF2250A	Aluminised Lipped Flange - 2¼" x 22°	
SLF2500A	Aluminised Lipped Flange - 2½" x 22°	
SLF3000A	Aluminised Lipped Flange - 3" x 22°	
SLF3500A	Aluminised Lipped Flange - 3½" x 22°	
SLF4000A	Aluminised Lipped Flange - 4" x 22°	
SLF4500A	Aluminised Lipped Flange - 4½" x 22°	
SLF5000A	Aluminised Lipped Flange - 5" x 22°	
SLF6000A	Aluminised Lipped Flange - 6" x 22°	
Stainless Steel Lipped Flange 22° (Grade 304) (Plain)		
SLF2000SS	Stainless Steel Lipped Flange - 2" x 22°	
SLF2500SS	Stainless Steel Lipped Flange - 2½" x 22°	
SLF3000SS	Stainless Steel Lipped Flange - 3" x 22°	
SLF3500SS	Stainless Steel Lipped Flange - 3½" x 22°	
SLF4000SS	Stainless Steel Lipped Flange - 4" x 22°	
SLF5000SS	Stainless Steel Lipped Flange - 5" x 22°	
SLF6000SS	Stainless Steel Lipped Flange - 6" x 22°	
Mild Steel Expanded Lipped Flange 22°		
ELF2000	Mild Steel Expanded Lipped Flange - 2" x 22°	
ELF2250	Mild Steel Expanded Lipped Flange - 2¼" x 22°	
ELF2500	Mild Steel Expanded Lipped Flange - 2½" x 22°	
ELF2750	Mild Steel Expanded Lipped Flange - 2¾" x 22°	
ELF3000	Mild Steel Expanded Lipped Flange - 3" x 22°	
ELF3500	Mild Steel Expanded Lipped Flange - 3½" x 22°	
ELF4000	Mild Steel Expanded Lipped Flange - 4" x 22°	
ELF4500	Mild Steel Expanded Lipped Flange - 4½" x 22°	
ELF5000	Mild Steel Expanded Lipped Flange - 5" x 22°	
ELF6000	Mild Steel Expanded Lipped Flange - 6" x 22°	
Aluminised Expanded Lipped Flange 22° (Plain)		
ELF2000A	Aluminised Expanded Lipped Flange - 2" x 22°	
ELF2250A	Aluminised Expanded Lipped Flange - 2¼" x 22°	
ELF2500A	Aluminised Expanded Lipped Flange - 2½" x 22°	
ELF3000A	Aluminised Expanded Lipped Flange - 3" x 22°	
ELF3500A	Aluminised Expanded Lipped Flange - 3½" x 22°	
ELF4000A	Aluminised Expanded Lipped Flange - 4" x 22°	
ELF4500A	Aluminised Expanded Lipped Flange - 4½" x 22°	
ELF5000A	Aluminised Expanded Lipped Flange - 5" x 22°	
ELF6000A	Aluminised Expanded Lipped Flange - 6" x 22°	

CHROMEND SUPPLY CO. – TRUCK CATALOGUE 2007

Stainless Steel Expanded Lipped Flange 22° (Grade 304) (Plain)		
ELF2000SS	Stainless Steel Expanded Lipped Flange - 2" x 22°	
ELF2500SS	Stainless Steel Expanded Lipped Flange - 2½" x 22°	
ELF3000SS	Stainless Steel Expanded Lipped Flange - 3" x 22°	
ELF3500SS	Stainless Steel Expanded Lipped Flange - 3½" x 22°	
ELF4000SS	Stainless Steel Expanded Lipped Flange - 4" x 22°	
ELF5000SS	Stainless Steel Expanded Lipped Flange - 5" x 22°	
ELF6000SS	Stainless Steel Expanded Lipped Flange - 6" x 22°	
Tube Connectors		
VBT350	3½" x Leaktight Reusable Joint - Kit includes two flanges and one V band clamp	
VBT400	4" x Leaktight Reusable Joint - Kit includes two flanges and one V band clamp	
VBT500	5" x Leaktight Reusable Joint - Kit includes two flanges and one V band clamp	
Beaded Couplers		
BC102	Mild Steel Beaded Coupler x 4"	
BC102A	Aluminised Beaded Coupler x 4"	
BC114V	Mild Steel Beaded Coupler x 4½" - Volvo	
BC127	Mild Steel Beaded Coupler x 5"	
BC127A	Aluminised Beaded Coupler x 5"	
V Band Clamps - Stainless Steel		
89500K	V Band Clamp - 3" - Cummins V903, Ford 370 & 429, E5HZ-5A321-B	
89501K	V Band Clamp - 3½" - Cummins VT555	
89503K	V Band Clamp - 5" - Cummins T50 Turbo M11	
89505K	V Band Clamp - 3" - Detroit Diesel 6V71	
89506K	V Band Clamp - 3½" - Detroit Diesel 8V71	
89507K	V Band Clamp - 4" - Detroit Diesel 6-71	
89508K	V Band Clamp - 4" - Detroit Diesel 8-2N	
89509K	V Band Clamp - 4" - Detroit Diesel 8.2T, GM2295978	
89510K	V Band Clamp - 4.88" - Detroit Diesel 8V71T, 6V92T, 8V82T	
89512K	V Band Clamp - 3½" - IH DT466 & Connector Ends	
89520K	V Band Clamp - 4" - Cat 3126T & 3176T, Cummins L10 & M10	
89530K	V Band Clamp - 3" - Ford D9HT-51210-DA, US Cummins	
89531K	V Band Clamp - 3½" - Cat 3208T, Ford 6.6 & 7.8, E2HT5A212A	
89532K	V Band Clamp - 4" - Mack 11ME29	
89533K	V Band Clamp - 4" - Mack 48RU2341	
89571K	V Band Clamp - 2¾" - Cummins B	
89573K	V Band Clamp - 3½" - Cummins C	
90530K	V Band Clamp - 5" - Detroit Diesel 8V71 Special Manifold	
90603K	V Band Clamp - 2½" - Cummins V903, Ford 370 & 429, E5HZ-5A321-B	

CHROMEND SUPPLY CO. – TRUCK CATALOGUE 2007

Adaptors / Reducers OD/OD - Mild Steel		
EXA20225	Mild Steel Adaptor/Reducer 2" OD x 2¼" OD x 5" overall length	
EXA2025	Mild Steel Adaptor/Reducer 2" OD x 2½" OD x 5" overall length	
EXA2030	Mild Steel Adaptor/Reducer 2" OD x 3" OD x 5" overall length	
EXA225250	Mild Steel Adaptor/Reducer 2¼" OD x 2½" OD x 5" overall length	
EXA25275	Mild Steel Adaptor/Reducer 2½" OD x 2¾" OD x 5" overall length	
EXA2530	Mild Steel Adaptor/Reducer 2½" OD x 3" OD x 5" overall length	
EXA27530	Mild Steel Adaptor/Reducer 2¾" OD x 3" OD x 5" overall length	
EXA3035	Mild Steel Adaptor/Reducer 3" OD x 3½" OD x 5" overall length	
EXA3040	Mild Steel Adaptor/Reducer 3" OD x 4" OD x 5" overall length	
EXA3540	Mild Steel Adaptor/Reducer 3½" OD x 4" OD x 5" overall length	
EXA4045	Mild Steel Adaptor/Reducer 4" OD x 4½" OD x 5" overall length	
EXA4050	Mild Steel Adaptor/Reducer 4" OD x 5" OD x 5" overall length	
EXA4550	Mild Steel Adaptor/Reducer 4½" OD x 5" OD x 5" overall length	
EXA5055	Mild Steel Adaptor/Reducer 5" OD x 5½" OD x 5" overall length	
EXA5060	Mild Steel Adaptor/Reducer 5" OD x 6" OD x 5" overall length	
Adaptors / Reducers OD-OD - Aluminised Steel		
EXA20225A	Aluminised Adaptor/Reducer 2" OD x 2¼" OD x 5" overall length	
EXA2025A	Aluminised Adaptor/Reducer 2" OD x 2½" OD x 5" overall length	
EXA2030A	Aluminised Adaptor/Reducer 2" OD x 3" OD x 5" overall length	
EXA225250A	Aluminised Adaptor/Reducer 2¼" OD x 2½" OD x 5" overall length	
EXA25275A	Aluminised Adaptor/Reducer 2½" OD x 2¾" OD x 5" overall length	
EXA2530A	Aluminised Adaptor/Reducer 2½" OD x 3" OD x 5" overall length	
EXA27530A	Aluminised Adaptor/Reducer 2¾" OD x 3" OD x 5" overall length	
EXA3035A	Aluminised Adaptor/Reducer 3" OD x 3½" OD x 5" overall length	
EXA3040A	Aluminised Adaptor/Reducer 3" OD x 4" OD x 5" overall length	
EXA3540A	Aluminised Adaptor/Reducer 3½" OD x 4" OD x 5" overall length	
EXA4045A	Aluminised Adaptor/Reducer 4" OD x 4½" OD x 5" overall length	
EXA4050A	Aluminised Adaptor/Reducer 4" OD x 5" OD x 5" overall length	
EXA4550A	Aluminised Adaptor/Reducer 4½" OD x 5" OD x 5" overall length	
EXA5055A	Aluminised Adaptor/Reducer 5" OD x 5½" OD x 5" overall length	
EXA5060A	Aluminised Adaptor/Reducer 5" OD x 6" OD x 5" overall length	
Adaptors / Reducers OD/OD - Stainless Steel (304)		
EXA20225SS	Stainless Steel Adaptor/Reducer 2" OD x 2¼" OD x 5" overall length	
EXA2025SS	Stainless Steel Adaptor/Reducer 2" OD x 2½" OD x 5" overall length	
EXA2030SS	Stainless Steel Adaptor/Reducer 2" OD x 3" OD x 5" overall length	
EXA25275SS	Stainless Steel Adaptor/Reducer 2½" OD x 2¾" OD x 5" overall length	
EXA2530SS	Stainless Steel Adaptor/Reducer 2½" OD x 3" OD x 5" overall length	
EXA3035SS	Stainless Steel Adaptor/Reducer 3" OD x 3½" OD x 5" overall length	
EXA3040SS	Stainless Steel Adaptor/Reducer 3" OD x 4" OD x 5" overall length	

CHROMEND SUPPLY CO. – TRUCK CATALOGUE 2007

Adaptors / Reducers OD/OD - Stainless Steel

EXA3540SS	Stainless Steel Adaptor/Reducer 3½" OD x 4" OD x 5" overall length	
EXA4045SS	Stainless Steel Adaptor/Reducer 4" OD x 4½" OD x 5" overall length	
EXA4050SS	Stainless Steel Adaptor/Reducer 4" OD x 5" OD x 5" overall length	
EXA5060SS	Stainless Steel Adaptor/Reducer 5" OD x 6" OD x 5" overall length	

Single Coupler - ID/OD - Mild Steel

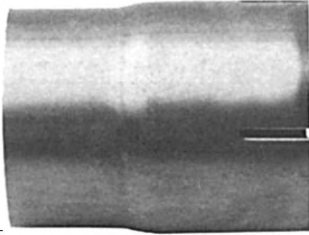
EXS2000	Mild Steel Single Coupler 2" ID/OD - 51mm x 5" overall length	
EXS2250	Mild Steel Single Coupler 2¼" ID/OD - 57mm x 5" overall length	
EXS2500	Mild Steel Single Coupler 2½" ID/OD - 63mm x 5" overall length	
EXS2750	Mild Steel Single Coupler 2¾" ID/OD - 70mm x 5" overall length	
EXS3000	Mild Steel Single Coupler 3" ID/OD - 76mm x 5" overall length	
EXS3500	Mild Steel Single Coupler 3½" ID/OD - 89mm x 5" overall length	
EXS4000	Mild Steel Single Coupler 4" ID/OD - 102mm x 5" overall length	
EXS4500	Mild Steel Single Coupler 4½" ID/OD - 114mm x 5" overall length	
EXS5000	Mild Steel Single Coupler 5" ID/OD - 127mm x 5" overall length	
EXS5500	Mild Steel Single Coupler 5½" ID/OD - 140mm x 5" overall length	
EXS6000	Mild Steel Single Coupler 6" ID/OD - 152mm x 5" overall length	

Single Coupler - ID-OD - Aluminised Steel

EXS2000A	Aluminised Single Coupler 2" ID/OD - 51mm x 5" overall length	
EXS2250A	Aluminised Single Coupler 2¼" ID/OD - 57mm x 5" overall length	
EXS2500A	Aluminised Single Coupler 2½" ID/OD - 63mm x 5" overall length	
EXS3000A	Aluminised Single Coupler 3" ID/OD - 76mm x 5" overall length	
EXS3500A	Aluminised Single Coupler 3½" ID/OD - 89mm x 5" overall length	
EXS4000A	Aluminised Single Coupler 4" ID/OD - 102mm x 5" overall length	
EXS4500A	Aluminised Single Coupler 4½" ID/OD - 114mm x 5" overall length	
EXS5000A	Aluminised Single Coupler 5" ID/OD - 127mm x 5" overall length	
EXS6000A	Aluminised Single Coupler 6" ID/OD - 152mm x 5" overall length	

Single Coupler - ID/OD - Stainless Steel (304)

EXS2000SS	Stainless Steel Single Coupler 2" ID/OD - 51mm x 5" overall length	
EXS2500SS	Stainless Steel Single Coupler 2½" ID/OD - 63mm x 5" overall length	
EXS3000SS	Stainless Steel Single Coupler 3" ID/OD - 76mm x 5" overall length	
EXS3500SS	Stainless Steel Single Coupler 3½" ID/OD - 89mm x 5" overall length	
EXS4000SS	Stainless Steel Single Coupler 4" ID/OD - 102mm x 5" overall length	
EXS5000SS	Stainless Steel Single Coupler 5" ID/OD - 127mm x 5" overall length	
EXS6000SS	Stainless Steel Single Coupler 6" ID/OD - 127mm x 5" overall length	

Double Coupler - ID/ID - Mild Steel

EXD2000	Mild Steel Double Coupler 2" ID/ID - 51mm x 5" overall length	
EXD2250	Mild Steel Double Coupler 2¼" ID/ID - 57mm x 5" overall length	
EXD2500	Mild Steel Double Coupler 2½" ID/ID - 63mm x 5" overall length	
EXD2750	Mild Steel Double Coupler 2¾" ID/ID - 70mm x 5" overall length	

CHROMEND SUPPLY CO. – TRUCK CATALOGUE 2007

Double Coupler - ID/ID - Mild Steel

EXD3000	Mild Steel Double Coupler 3" ID/ID - 76mm x 5" overall length		
EXD3500	Mild Steel Double Coupler 3½" ID/ID - 89mm x 5" overall length		
EXD4000	Mild Steel Double Coupler 4" ID/ID - 102mm x 5" overall length		
EXD4500	Mild Steel Double Coupler 4½" ID/ID - 114mm x 5" overall length		
EXD5000	Mild Steel Double Coupler 5" ID/ID - 127mm x 5" overall length		
EXD5500	Mild Steel Double Coupler 5½" ID/ID - 140mm x 5" overall length		
EXD6000	Mild Steel Double Coupler 6" ID/ID - 152mm x 5" overall length		

Double Coupler - ID/ID - Aluminised Steel

EXD2000A	Aluminised Double Coupler 2" ID/ID - 51mm x 5" overall length		
EXD2250A	Aluminised Double Coupler 2¼" ID/ID - 57mm x 5" overall length		
EXD2500A	Aluminised Double Coupler 2½" ID/ID - 63mm x 5" overall length		
EXD3000A	Aluminised Double Coupler 3" ID/ID - 76mm x 5" overall length		
EXD3500A	Aluminised Double Coupler 3½" ID/ID - 89mm x 5" overall length		
EXD4000A	Aluminised Double Coupler 4" ID/ID - 102mm x 5" overall length		
EXD4500A	Aluminised Double Coupler 4½" ID/ID - 114mm x 5" overall length		
EXD5000A	Aluminised Double Coupler 5" ID/ID - 127mm x 5" overall length		
EXD6000A	Aluminised Double Coupler 6" ID/ID - 152mm x 5" overall length		

Double Coupler - ID/ID - Stainless Steel (304)

EXD2000SS	Stainless Steel Double Coupler 2" ID/ID - 51mm x 5" overall length		
EXD2500SS	Stainless Steel Double Coupler 2½" ID/ID - 63mm x 5" overall length		
EXD3000SS	Stainless Steel Double Coupler 3" ID/ID - 76mm x 5" overall length		
EXD3500SS	Stainless Steel Double Coupler 3½" ID/ID - 89mm x 5" overall length		
EXD4000SS	Stainless Steel Double Coupler 4" ID/ID - 102mm x 5" overall length		
EXD5000SS	Stainless Steel Double Coupler 5" ID/ID - 114mm x 5" overall length		
EXD6000SS	Stainless Steel Double Coupler 6" ID/ID - 127mm x 5" overall length		

Stainless Steel Hose Clamps

SMP2P	35-53mm Stainless Steel Solid Band (non-perforated) Heavy Duty		
SMP3P	52-70mm Stainless Steel Solid Band (non-perforated) Heavy Duty		
SMP4P	65-90mm Stainless Steel Solid Band (non-perforated) Heavy Duty		
SMP5P	85-110mm Stainless Steel Solid Band (non-perforated) Heavy Duty		
SMP6P	105-130mm Stainless Steel Solid Band (non-perforated) Heavy Duty		
SMP7P	130-155mm Stainless Steel Solid Band (non-perforated) Heavy Duty		
SMP8P	155-180mm Stainless Steel Solid Band (non-perforated) Heavy Duty		

Exhaust Clamps - Flat Back CAD Plated

FBC3000	Flat Back Clamp - CAD Plated - To suit pipe size 3" to 3½"		
FBC3500	Flat Back Clamp - CAD Plated - To suit pipe size 3½" to 3¾"		
FBC4000	Flat Back Clamp - CAD Plated - To suit pipe size 4" to 4½"		
FBC4500	Flat Back Clamp - CAD Plated - To suit pipe size 4½" to 4¾"		
FBC5000	Flat Back Clamp - CAD Plated - To suit pipe size 5" to 5½"		

CHROMEND SUPPLY CO. – TRUCK CATALOGUE 2007

Exhaust Clamps - Flat Back CAD Plated			
FBC5500	Flat Back Clamp - CAD Plated - To suit pipe size 5½" to 5⅝"		
FBC6000	Flat Back Clamp - CAD Plated - To suit pipe size 6" to 6⅞"		
FBC7000	Flat Back Clamp - CAD Plated - To suit pipe size 7" to 7⅞"		
FBC8000	Flat Back Clamp - CAD Plated - To suit pipe size 8" to 8⅞"		
Exhaust Clamps - Flat Back (Chrome Plated)			
FBC300C	Flat Back Clamp - Chrome Plated - To suit pipe size 3" to 3⅜"		
FBC350C	Flat Back Clamp - Chrome Plated - To suit pipe size 3½" to 3⅞"		
FBC400C	Flat Back Clamp - Chrome Plated - To suit pipe size 4" to 4⅞"		
FBC450C	Flat Back Clamp - Chrome Plated - To suit pipe size 4½" to 4⅞"		
FBC500C	Flat Back Clamp - Chrome Plated - To suit pipe size 5" to 5⅞"		
FBC600C	Flat Back Clamp - Chrome Plated - To suit pipe size 6" to 6⅞"		
Lap Type Clamps - Aluminised Steel - Rigid to Flex Clamps (Preformed)			
TCL200	Aluminised Lap Type Clamp - To suit 2" OD - (51mm) Tube Size		
TCL225	Aluminised Lap Type Clamp - To suit 2¼" OD - (57mm) Tube Size		
TCL250	Aluminised Lap Type Clamp - To suit 2½" OD - (63mm) Tube Size		
TCL275	Aluminised Lap Type Clamp - To suit 2¾" OD - (70mm) Tube Size		
TCL300	Aluminised Lap Type Clamp - To suit 3" OD - (76mm) Tube Size		
TCL350	Aluminised Lap Type Clamp - To suit 3½" OD - (89mm) Tube Size		
TCL400	Aluminised Lap Type Clamp - To suit 4" OD - (102mm) Tube Size		
TCL450	Aluminised Lap Type Clamp - To suit 4½" OD - (114mm) Tube Size		
TCL500	Aluminised Lap Type Clamp - To suit 5" OD - (127mm) Tube Size		
TCL600	Aluminised Lap Type Clamp - To suit 6" OD - (152mm) Tube Size		
TCL BOLTS	Aluminised Lap Type Clamp - Bolts Only		
Lap Type Clamps - Stainless Steel - Rigid to Flex Clamps (Preformed)			
TCL200SS	Stainless Steel Lap Type Clamp - To suit 2" OD - (51mm) Tube Size		
TCL225SS	Stainless Steel Lap Type Clamp - To suit 2¼" OD - (57mm) Tube Size		
TCL250SS	Stainless Steel Lap Type Clamp - To suit 2½" OD - (63mm) Tube Size		
TCL275SS	Stainless Steel Lap Type Clamp - To suit 2¾" OD - (70mm) Tube Size		
TCL300SS	Stainless Steel Lap Type Clamp - To suit 3" OD - (76mm) Tube Size		
TCL350SS	Stainless Steel Lap Type Clamp - To suit 3½" OD - (89mm) Tube Size		
TCL400SS	Stainless Steel Lap Type Clamp - To suit 4" OD - (102mm) Tube Size		
TCL450SS	Stainless Steel Lap Type Clamp - To suit 4½" OD - (114mm) Tube Size		
TCL500SS	Stainless Steel Lap Type Clamp - To suit 5" OD - (127mm) Tube Size		
TCL600SS	Stainless Steel Lap Type Clamp - To suit 6" OD - (152mm) Tube Size		
Uni Bolt Clamps - Stainless Steel (304 Stainless Steel Band & Bolt)			
UB24-26S	Stainless Steel Band & Bolt - 24-26mm Min/Max - 16mm Clamp Width x M5 Bolt		
UB26-28S	Stainless Steel Band & Bolt - 26-28mm Min/Max - 16mm Clamp Width x M5 Bolt		
UB29-31S	Stainless Steel Band & Bolt - 29-31mm Min/Max - 20mm Clamp Width x M6 Bolt		
UB32-35S	Stainless Steel Band & Bolt - 32-35mm Min/Max - 20mm Clamp Width x M6 Bolt		

CHROMEND SUPPLY CO. – TRUCK CATALOGUE 2007

Uni Bolt Clamps - Stainless Steel		
UB38-41S	Stainless Steel Band & Bolt - 38-41mm Min/Max - 20mm Clamp Width x M6 Bolt	
UB40-43S	Stainless Steel Band & Bolt - 40-43mm Min/Max - 20mm Clamp Width x M6 Bolt	
UB44-47S	Stainless Steel Band & Bolt - 44-47mm Min/Max - 20mm Clamp Width x M6 Bolt	
UB46-49S	Stainless Steel Band & Bolt - 46-49mm Min/Max - 20mm Clamp Width x M6 Bolt	
UB48-51S	Stainless Steel Band & Bolt - 48-51mm Min/Max - 20mm Clamp Width x M6 Bolt	
UB50-53S	Stainless Steel Band & Bolt - 50-53mm Min/Max - 20mm Clamp Width x M6 Bolt	
UB52-55S	Stainless Steel Band & Bolt - 52-55mm Min/Max - 20mm Clamp Width x M6 Bolt	
UB56-59S	Stainless Steel Band & Bolt - 56-59mm Min/Max - 20mm Clamp Width x M6 Bolt	
UB58-61S	Stainless Steel Band & Bolt - 58-61mm Min/Max - 20mm Clamp Width x M6 Bolt	
UB62-65S	Stainless Steel Band & Bolt - 62-65mm Min/Max - 20mm Clamp Width x M6 Bolt	
UB64-67S	Stainless Steel Band & Bolt - 64-67mm Min/Max - 24mm Clamp Width x M8 Bolt	
UB68-73S	Stainless Steel Band & Bolt - 68-73mm Min/Max - 24mm Clamp Width x M8 Bolt	
UB71-76S	Stainless Steel Band & Bolt - 71-76mm Min/Max - 24mm Clamp Width x M8 Bolt	
UB74-79S	Stainless Steel Band & Bolt - 74-79mm Min/Max - 24mm Clamp Width x M8 Bolt	
UB77-82S	Stainless Steel Band & Bolt - 77-82mm Min/Max - 24mm Clamp Width x M8 Bolt	
UB80-85S	Stainless Steel Band & Bolt - 80-85mm Min/Max - 24mm Clamp Width x M8 Bolt	
UB83-88S	Stainless Steel Band & Bolt - 83-88mm Min/Max - 24mm Clamp Width x M8 Bolt	
UB89-94S	Stainless Steel Band & Bolt - 89-94mm Min/Max - 24mm Clamp Width x M8 Bolt	
UB95-100S	Stainless Steel Band & Bolt - 95-100mm Min/Max - 24mm Clamp Width x M8 Bolt	
UB98-103S	Stainless Steel Band & Bolt - 98-103mm Min/Max - 24mm Clamp Width x M8 Bolt	
UB101-107S	Stainless Steel Band & Bolt - 101-107mm Min/Max - 24mm Clamp Width x M8 Bolt	
UB104-112S	Stainless Steel Band & Bolt - 104-112mm Min/Max - 24mm Clamp Width x M8 Bolt	
UB113-121S	Stainless Steel Band & Bolt - 113-121mm Min/Max - 24mm Clamp Width x M8 Bolt	
UB122-130S	Stainless Steel Band & Bolt - 122-130mm Min/Max - 24mm Clamp Width x M8 Bolt	
UB126-134S	Stainless Steel Band & Bolt - 126-134mm Min/Max - 24mm Clamp Width x M8 Bolt	
UB131-139S	Stainless Steel Band & Bolt - 131-139mm Min/Max - 24mm Clamp Width x M8 Bolt	
UB140-148S	Stainless Steel Band & Bolt - 140-148mm Min/Max - 24mm Clamp Width x M8 Bolt	
UB149-161S	Stainless Steel Band & Bolt - 148-161mm Min/Max - 24mm Clamp Width x M8 Bolt	
UB162-174S	Stainless Steel Band & Bolt - 162-174mm Min/Max - 26mm Clamp Width x M10 Bolt	
UB175-187S	Stainless Steel Band & Bolt - 175-181mm Min/Max - 26mm Clamp Width x M10 Bolt	
UB201-213S	Stainless Steel Band & Bolt - 201-213mm Min/Max - 26mm Clamp Width x M10 Bolt	
UB214-226S	Stainless Steel Band & Bolt - 214-226mm Min/Max - 26mm Clamp Width x M10 Bolt	
UB227-239S	Stainless Steel Band & Bolt - 227-239mm Min/Max - 26mm Clamp Width x M10 Bolt	
UB253-265S	Stainless Steel Band & Bolt - 253-265mm Min/Max - 26mm Clamp Width x M10 Bolt	
Uni Bolt Clamps - Zinc Plated Bolt & Stainless Steel Band		
UB24-26D	Zinc Plated Bolt & Stainless Steel Band - 24-26mm Min/Max - 16mm Clamp Width x M5 Bolt	
UB26-28D	Zinc Plated Bolt & Stainless Steel Band - 26-28mm Min/Max - 16mm Clamp Width x M5 Bolt	
UB32-35D	Zinc Plated Bolt & Stainless Steel Band - 32-35mm Min/Max - 20mm Clamp Width x M6 Bolt	
UB38-41D	Zinc Plated Bolt & Stainless Steel Band - 38-41mm Min/Max - 20mm Clamp Width x M6 Bolt	

CHROMEND SUPPLY CO. – TRUCK CATALOGUE 2007



Uni Bolt Clamps - Zinc Plated Bolt & Stainless Steel Band

UB40-43D	Zinc Plated Bolt & Stainless Steel Band - 40-43mm Min/Max - 20mm Clamp Width x M6 Bolt	
UB44-47D	Zinc Plated Bolt & Stainless Steel Band - 44-47mm Min/Max - 20mm Clamp Width x M6 Bolt	
UB46-49D	Zinc Plated Bolt & Stainless Steel Band - 46-49mm Min/Max - 20mm Clamp Width x M6 Bolt	
UB48-51D	Zinc Plated Bolt & Stainless Steel Band - 48-51mm Min/Max - 20mm Clamp Width x M6 Bolt	
UB50-53D	Zinc Plated Bolt & Stainless Steel Band - 50-53mm Min/Max - 20mm Clamp Width x M6 Bolt	
UB52-55D	Zinc Plated Bolt & Stainless Steel Band - 52-55mm Min/Max - 20mm Clamp Width x M6 Bolt	
UB56-59D	Zinc Plated Bolt & Stainless Steel Band - 56-59mm Min/Max - 20mm Clamp Width x M6 Bolt	
UB58-61D	Zinc Plated Bolt & Stainless Steel Band - 58-61mm Min/Max - 20mm Clamp Width x M6 Bolt	
UB62-65D	Zinc Plated Bolt & Stainless Steel Band - 62-65mm Min/Max - 20mm Clamp Width x M6 Bolt	
UB64-67D	Zinc Plated Bolt & Stainless Steel Band - 64-67mm Min/Max - 24mm Clamp Width x M8 Bolt	
UB68-73D	Zinc Plated Bolt & Stainless Steel Band - 68-73mm Min/Max - 24mm Clamp Width x M8 Bolt	
UB71-76D	Zinc Plated Bolt & Stainless Steel Band - 71-76mm Min/Max - 24mm Clamp Width x M8 Bolt	
UB74-79D	Zinc Plated Bolt & Stainless Steel Band - 74-79mm Min/Max - 24mm Clamp Width x M8 Bolt	
UB77-82D	Zinc Plated Bolt & Stainless Steel Band - 77-82mm Min/Max - 24mm Clamp Width x M8 Bolt	
UB80-85D	Zinc Plated Bolt & Stainless Steel Band - 80-85mm Min/Max - 24mm Clamp Width x M8 Bolt	
UB83-88D	Zinc Plated Bolt & Stainless Steel Band - 83-88mm Min/Max - 24mm Clamp Width x M8 Bolt	
UB89-94D	Zinc Plated Bolt & Stainless Steel Band - 89-94mm Min/Max - 24mm Clamp Width x M8 Bolt	
UB95-100D	Zinc Plated Bolt & Stainless Steel Band - 95-100mm Min/Max - 24mm Clamp Width x M8 Bolt	
UB98-103D	Zinc Plated Bolt & Stainless Steel Band - 98-103mm Min/Max - 24mm Clamp Width x M8 Bolt	
UB101-107D	Zinc Plated Bolt & Stainless Steel Band - 101-107mm Min/Max - 24mm Clamp Width x M8 Bolt	
UB104-112D	Zinc Plated Bolt & Stainless Steel Band - 104-112mm Min/Max - 24mm Clamp Width x M8 Bolt	
UB113-121D	Zinc Plated Bolt & Stainless Steel Band - 113-121mm Min/Max - 24mm Clamp Width x M8 Bolt	
UB122-130D	Zinc Plated Bolt & Stainless Steel Band - 122-130mm Min/Max - 24mm Clamp Width x M8 Bolt	
UB126-134D	Zinc Plated Bolt & Stainless Steel Band - 126-134mm Min/Max - 24mm Clamp Width x M8 Bolt	
UB131-139D	Zinc Plated Bolt & Stainless Steel Band - 131-139mm Min/Max - 24mm Clamp Width x M8 Bolt	
UB140-148D	Zinc Plated Bolt & Stainless Steel Band - 140-148mm Min/Max - 24mm Clamp Width x M8 Bolt	
UB149-161D	Zinc Plated Bolt & Stainless Steel Band - 148-161mm Min/Max - 24mm Clamp Width x M8 Bolt	
UB162-174D	Zinc Plated Bolt & Stainless Steel Band - 162-174mm Min/Max - 26mm Clamp Width x M10 Bolt	
UB175-187D	Zinc Plated Bolt & Stainless Steel Band - 175-181mm Min/Max - 26mm Clamp Width x M10 Bolt	
UB201-213D	Zinc Plated Bolt & Stainless Steel Band - 201-213mm Min/Max - 26mm Clamp Width x M10 Bolt	
UB214-226D	Zinc Plated Bolt & Stainless Steel Band - 214-226mm Min/Max - 26mm Clamp Width x M10 Bolt	
UB227-239D	Zinc Plated Bolt & Stainless Steel Band - 227-239mm Min/Max - 26mm Clamp Width x M10 Bolt	
UB253-265D	Zinc Plated Bolt & Stainless Steel Band - 253-265mm Min/Max - 26mm Clamp Width x M10 Bolt	

Single Bolt Clamp - Aluminised Steel

SBC200	Aluminised Single Bolt Clamp - 2" diameter - To suit 2 1/8" ID pipe or muffler spigot	
SBC225	Aluminised Single Bolt Clamp - 2 1/4" diameter - To suit 2 3/8" ID pipe or muffler spigot	
SBC250	Aluminised Single Bolt Clamp - 2 1/2" diameter - To suit 2 5/8" ID pipe or muffler spigot	
SBC275	Aluminised Single Bolt Clamp - 2 3/4" diameter - To suit 2 7/8" ID pipe or muffler spigot	
SBC300	Aluminised Single Bolt Clamp - 3" diameter - To suit 3 1/8" ID pipe or muffler spigot	

CHROMEND SUPPLY CO. – TRUCK CATALOGUE 2007

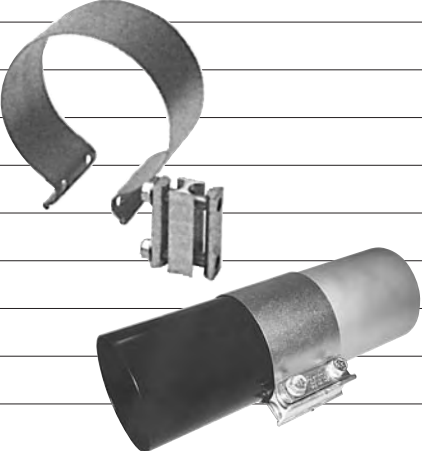
Single Bolt Clamp - Aluminised Steel		
SBC350	Aluminised Single Bolt Clamp - 3½" diameter - To suit 3⅝" ID pipe or muffler spigot	
SBC400	Aluminised Single Bolt Clamp - 4" diameter - To suit 4⅞" ID pipe or muffler spigot	
SBC450	Aluminised Single Bolt Clamp - 4½" diameter - To suit 4⅝" ID pipe or muffler spigot	
SBC500	Aluminised Single Bolt Clamp - 5" diameter - To suit 5⅞" ID pipe or muffler spigot	
SBC600	Aluminised Single Bolt Clamp - 6" diameter - To suit 6⅞" ID pipe or muffler spigot	
Single Bolt Clamp - Stainless Steel		
SBC200SS	Stainless Steel Single Bolt Clamp - 2" diameter - To suit 2⅞" ID pipe or muffler spigot	
SBC225SS	Stainless Steel Single Bolt Clamp - 2¼" diameter - To suit 2⅝" ID pipe or muffler spigot	
SBC250SS	Stainless Steel Single Bolt Clamp - 2½" diameter - To suit 2⅝" ID pipe or muffler spigot	
SBC275SS	Stainless Steel Single Bolt Clamp - 2¾" diameter - To suit 2⅞" ID pipe or muffler spigot	
SBC300SS	Stainless Steel Single Bolt Clamp - 3" diameter - To suit 3⅞" ID pipe or muffler spigot	
SBC350SS	Stainless Steel Single Bolt Clamp - 3½" diameter - To suit 3⅝" ID pipe or muffler spigot	
SBC400SS	Stainless Steel Single Bolt Clamp - 4" diameter - To suit 4⅞" ID pipe or muffler spigot	
SBC450SS	Stainless Steel Single Bolt Clamp - 4½" diameter - To suit 4⅝" ID pipe or muffler spigot	
SBC500SS	Stainless Steel Single Bolt Clamp - 5" diameter - To suit 5⅞" ID pipe or muffler spigot	
SBC600SS	Stainless Steel Single Bolt Clamp - 6" diameter - To suit 6⅞" ID pipe or muffler spigot	
Guillotine Clamp		
GUC234	Mild Steel Guillotine Clamp - 2¾" Nominal Diameter - 2⅞" Actual Diameter	
GUC300	Mild Steel Guillotine Clamp - 3" Nominal Diameter - 3⅞" Actual Diameter	
GUC325	Mild Steel Guillotine Clamp - 3¼" Nominal Diameter - 3⅝" Actual Diameter	
GUC350	Mild Steel Guillotine Clamp - 3½" Nominal Diameter - 3⅝" Actual Diameter	
GUC400	Mild Steel Guillotine Clamp - 4" Nominal Diameter - 4⅞" Actual Diameter	
GUC425	Mild Steel Guillotine Clamp - 4¼" Nominal Diameter - 4⅞" Actual Diameter	
GUC450	Mild Steel Guillotine Clamp - 4½" Nominal Diameter - 4⅝" Actual Diameter	
GUC500	Mild Steel Guillotine Clamp - 5" Nominal Diameter - 5⅞" Actual Diameter	
GUC600	Mild Steel Guillotine Clamp - 6" Nominal Diameter - 6⅞" Actual Diameter	
Butt Type Clamps - Aluminised (Rigid to Rigid)		
TCB200	Aluminised Butt Type Clamp - To suit 2" OD	
TCB225	Aluminised Butt Type Clamp - To suit 2¼" OD	
TCB250	Aluminised Butt Type Clamp - To suit 2½" OD	
TCB275	Aluminised Butt Type Clamp - To suit 2¾" OD	
TCB300	Aluminised Butt Type Clamp - To suit 3" OD	
TCB350	Aluminised Butt Type Clamp - To suit 3½" OD	
TCB400	Aluminised Butt Type Clamp - To suit 4" OD	
TCB450	Aluminised Butt Type Clamp - To suit 4½" OD	
TCB500	Aluminised Butt Type Clamp - To suit 5" OD	
TCB600	Aluminised Butt Type Clamp - To suit 6" OD	

CHROMEND SUPPLY CO. – TRUCK CATALOGUE 2007

Butt Type Clamps - S/S Easyseal Clamp (Rigid to Rigid or Rigid to Flex - Instant Form)

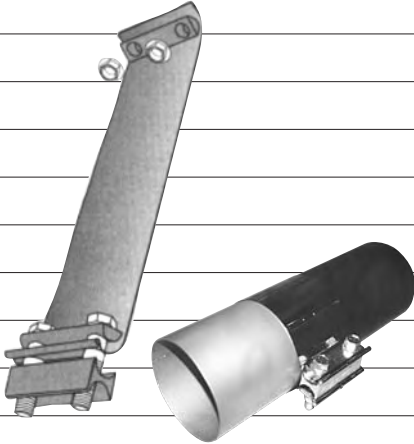
TSSL200	Stainless Steel Easyseal Clamp - To suit 2" OD		
TSSL225	Stainless Steel Easyseal Clamp - To suit 2¼" OD		
TSSL250	Stainless Steel Easyseal Clamp - To suit 2½" OD		
TSSL275	Stainless Steel Easyseal Clamp - To suit 2¾" OD		
TSSL300	Stainless Steel Easyseal Clamp - To suit 3" OD		
TSSL350	Stainless Steel Easyseal Clamp - To suit 3½" OD		
TSSL400	Stainless Steel Easyseal Clamp - To suit 4" OD		
TSSL450	Stainless Steel Easyseal Clamp - To suit 4½" OD		
TSSL500	Stainless Steel Easyseal Clamp - To suit 5" OD		
TSSL600	Stainless Steel Easyseal Clamp - To suit 6" OD		

Y Junction Pieces - Aluminised

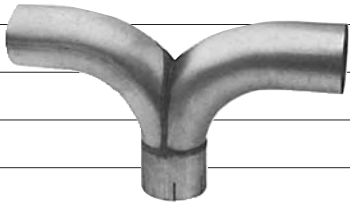
JY250A	Aluminised Y Junction Piece - 2½" OD Outlet x 2½" ID Inlet		
JY300A	Aluminised Y Junction Piece - 3" OD Outlet x 3" ID Inlet		
JY350A	Aluminised Y Junction Piece - 3½" OD Outlet x 3½" ID Inlet		
JY400A	Aluminised Y Junction Piece - 4" OD Outlet x 4" ID Inlet		
JY450A	Aluminised Y Junction Piece - 4½" OD Outlet x 4½" ID Inlet		
JY500A	Aluminised Y Junction Piece - 5" OD Outlet x 5" ID Inlet		
JY500KW	Aluminised Kenworth Y Junction Piece - 5" OD Outlet x 5" ID Inlet		
JY500SRA	Aluminised Tight Radius Y Junction Piece - 5" OD Outlet x 5" ID Inlet		
JY600A	Aluminised Y Junction Piece - 6" OD Outlet x 6" ID Inlet		

Tilt Cab Connectors - Mild Steel - Standard Ball & Bell

TCC4000	Mild Steel Tilt Cab Connector Set x 4" OD		
TCC5000	Mild Steel Tilt Cab Connector Set x 5" OD		
TCC6000	Mild Steel Tilt Cab Connector Set x 6" OD		

Tilt Cab Connectors - Aluminised - Standard Ball & Bell

TCC4000A	Aluminised Tilt Cab Connector Set x 4" OD		
TCC5000A	Aluminised Tilt Cab Connector Set x 5" OD		
TCC6000A	Aluminised Tilt Cab Connector Set x 6" OD		

Tilt Cab Connectors - Closer Tolerance - Aluminised - Larger Ball & Bell

TCC102LA	Aluminised Tilt Cab Connector Set x 4" OD (Closer Tolerance)		
TCC127LA	Aluminised Tilt Cab Connector Set x 5" OD (Closer Tolerance)		

Tilt Cab Connectors with 90° Elbow & Bracket

TCCSR590	Aluminised Tilt Cab Connector Set x 5" OD with 90° Elbow & Bracket		
TCC500B	Aluminised Bell Only		
TCCSR590-CP	Chrome Plated Tilt Cab Connector Set x 5" OD with 90° Elbow & Bracket		
TCC500B-CP	Chrome Plated Bell Only		

CHROMEND SUPPLY CO. – TRUCK CATALOGUE 2007

Silenced Raincaps - Zinc Plated

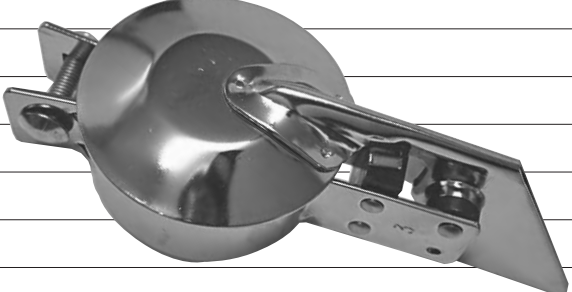
SRC150Z	1½" (38mm) Silent Raincap - Zinc Plated	
SRC175Z	1¾" (45mm) Silent Raincap - Zinc Plated	
SRC200Z	2" (51mm) Silent Raincap - Zinc Plated	
SRC225Z	2¼" (57mm) Silent Raincap - Zinc Plated	
SRC250Z	2½" (63mm) Silent Raincap - Zinc Plated	
SRC275Z	2¾" (70mm) Silent Raincap - Zinc Plated	
SRC300Z	3" (76mm) Silent Raincap - Zinc Plated	
SRC350Z	3½" (89mm) Silent Raincap - Zinc Plated	
SRC400Z	4" (102mm) Silent Raincap - Zinc Plated	
SRC450Z	4½" (114mm) Silent Raincap - Zinc Plated	
SRC500Z	5" (127mm) Silent Raincap - Zinc Plated	
SRC550Z	5½" (140mm) Silent Raincap - Zinc Plated	
SRC600Z	6" (152mm) Silent Raincap - Zinc Plated	
SRC700P	7" (178mm) Silent Raincap - Heat Painted	
SRC800P	8" (203mm) Silent Raincap - Heat Painted	
SRC1000P	10" (254mm) Silent Raincap - Heat Painted	
SRC1200P	12" (300mm) Silent Raincap - Heat Painted	

Silenced Raincaps - Chrome Plated

SRC200C	2" (51mm) Silent Raincap - Chrome Plated
SRC225C	2¼" (57mm) Silent Raincap - Chrome Plated
SRC250C	2½" (63mm) Silent Raincap - Chrome Plated
SRC275C	2¾" (70mm) Silent Raincap - Chrome Plated
SRC300C	3" (76mm) Silent Raincap - Chrome Plated
SRC350C	3½" (89mm) Silent Raincap - Chrome Plated
SRC400C	4" (102mm) Silent Raincap - Chrome Plated
SRC450C	4½" (114mm) Silent Raincap - Chrome Plated
SRC500C	5" (127mm) Silent Raincap - Chrome Plated
SRC600C	6" (152mm) Silent Raincap - Chrome Plated

360° Donut Bends - Seamless - Stainless Steel - Radius = 1 x diameter

DNO38SS	38mm (1½") Stainless Steel Seamless Donut	
DNO41SS	41mm (1⅝") Stainless Steel Seamless Donut	
DNO44SS	44mm (1¾") Stainless Steel Seamless Donut	
DNO47SS	47mm (1⅞") Stainless Steel Seamless Donut	
DNO51SS	51mm (2") Stainless Steel Seamless Donut	
DNO51SSL	Large Radius (1.5 x diameter) 51mm (2") Stainless Steel Seamless Donut	
DNO54SS	54mm (2⅛") Stainless Steel Seamless Donut	
DNO57SS	57mm (2¼") Stainless Steel Seamless Donut	
DNO60SS	60mm (2⅜") Stainless Steel Seamless Donut	
DNO63SS	63mm (2½") Stainless Steel Seamless Donut	

CHROMEND SUPPLY CO. – TRUCK CATALOGUE 2007

360° Donut Bends - Seamless - Stainless Steel - Radius = 1 x diameter

DNO76SS	76mm (3") Stainless Steel Seamless Donut	
DNO89SS	89mm (3½") Stainless Steel Seamless Donut	
DN102SS	102mm (4") Stainless Steel Seamless Donut	

360° Donut Bends - Seamless - Mild Steel - Radius = 1 x diameter

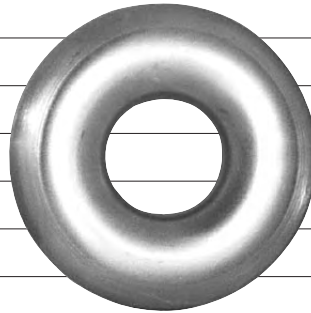

DNO38	38mm (1½") Mild Steel Seamless Donut	
DNO41	41mm (1⅝") Mild Steel Seamless Donut	
DNO41L	Large Radius (1.5 x diameter) 41mm (1⅝") Mild Steel Seamless Donut	
DNO44	44mm (1¾") Mild Steel Seamless Donut	
DNO44L	Large Radius (1.5 x diameter) 44mm (1¾") Mild Steel Seamless Donut	
DNO47	47mm (1⅞") Mild Steel Seamless Donut	
DNO47L	Large Radius (1.5 x diameter) 47mm (1⅞") Mild Steel Seamless Donut	
DNO51	51mm (2") Mild Steel Seamless Donut	
DNO51L	Large Radius (1.5 x diameter) 51mm (2") Mild Steel Seamless Donut	
DNO54	54mm (2⅛") Mild Steel Seamless Donut	
DNO57	57mm (2¼") Mild Steel Seamless Donut	
DNO60	60mm (2⅜") Mild Steel Seamless Donut	
DNO63	63mm (2½") Mild Steel Seamless Donut	
DNO76	76mm (3") Mild Steel Seamless Donut	
DNO89	89mm (3½") Mild Steel Seamless Donut	
DN102	102mm (4") Mild Steel Seamless Donut	
DN114	114mm (4½") Mild Steel Seamless Donut	
DN127	127mm (5") Mild Steel Seamless Donut	



360° Donut Bends - Welded - Mild Steel

MSD2000	2" (51mm) Mild Steel Welded Donut	
MSD2250	2¼" (57mm) Mild Steel Welded Donut	
MSD2500	2½" (63mm) Mild Steel Welded Donut	
MSD3000	3" (76mm) Mild Steel Welded Donut	
MSD3500	3½" (89mm) Mild Steel Welded Donut	
MSD4000	4" (102mm) Mild Steel Welded Donut	
MSD4500	4½" (114mm) Mild Steel Welded Donut	
MSD5000	5" (127mm) Mild Steel Welded Donut	
MSD6000	6" (152mm) Mild Steel Welded Donut	
MSD7000	7" (178mm) Mild Steel Welded Donut	
MSD8000	8" (203mm) Mild Steel Welded Donut	
MSD10000	10" (254mm) Mild Steel Welded Donut	

CHROMEND SUPPLY CO. – TRUCK CATALOGUE 2007

Gas Purifiers			
CSW3	Phone customer service for accurate sizing		
CSW4	Phone customer service for accurate sizing		
CSW5	Phone customer service for accurate sizing		
CSW6	Phone customer service for accurate sizing		
CSW7	Phone customer service for accurate sizing		
CSW8	Phone customer service for accurate sizing		
CSW10	Phone customer service for accurate sizing		
CSW12	Phone customer service for accurate sizing		
45° Expanded "Y" Junction Pieces - Mild Steel			
JX2030	2" Expanded to 3" - Y Junction Piece - Mild Steel		
JX2253	2¼" Expanded to 3" - Y Junction Piece - Mild Steel		
JX2540	2½" Expanded to 4" - Y Junction Piece - Mild Steel		
JX3040	3" Expanded to 4" - Y Junction Piece - Mild Steel		
JX3550	3½" Expanded to 5" - Y Junction Piece - Mild Steel		
JX4050	4" Expanded to 5" - Y Junction Piece - Mild Steel		
Chrome Plated Exhaust Stacks (Curved Top - Plain Inlet)			
2½"			
CS2524P	Curved & Deflected Chrome Stack 2½" x 24" (600mm) Long - Plain Inlet		
CS2536P	Curved & Deflected Chrome Stack 2½" x 36" (900mm) Long - Plain Inlet		
CS2548P	Curved & Deflected Chrome Stack 2½" x 48" (1200mm) Long - Plain Inlet		
CS2560P	Curved & Deflected Chrome Stack 2½" x 60" (1500mm) Long - Plain Inlet		
CS2572P	Curved & Deflected Chrome Stack 2½" x 72" (1800mm) Long - Plain Inlet		
2¾"			
CS27524P	Curved & Deflected Chrome Stack 2¾" x 24" (600mm) Long - Plain Inlet		
CS27536P	Curved & Deflected Chrome Stack 2¾" x 36" (900mm) Long - Plain Inlet		
CS27548P	Curved & Deflected Chrome Stack 2¾" x 48" (1200mm) Long - Plain Inlet		
CS27560P	Curved & Deflected Chrome Stack 2¾" x 60" (1500mm) Long - Plain Inlet		
CS27572P	Curved & Deflected Chrome Stack 2¾" x 72" (1800mm) Long - Plain Inlet		
3"			
CS3024P	Curved & Deflected Chrome Stack 3" x 24" (600mm) Long - Plain Inlet		
CS3036P	Curved & Deflected Chrome Stack 3" x 36" (900mm) Long - Plain Inlet		
CS3048P	Curved & Deflected Chrome Stack 3" x 48" (1200mm) Long - Plain Inlet		
CS3060P	Curved & Deflected Chrome Stack 3" x 60" (1500mm) Long - Plain Inlet		
CS3072P	Curved & Deflected Chrome Stack 3" x 72" (1800mm) Long - Plain Inlet		
3½"			
CS3524P	Curved & Deflected Chrome Stack 3½" x 24" (600mm) Long - Plain Inlet		
CS3536P	Curved & Deflected Chrome Stack 3½" x 36" (900mm) Long - Plain Inlet		
CS3548P	Curved & Deflected Chrome Stack 3½" x 48" (1200mm) Long - Plain Inlet		
CS3560P	Curved & Deflected Chrome Stack 3½" x 60" (1500mm) Long - Plain Inlet		

CHROMEND SUPPLY CO. – TRUCK CATALOGUE 2007

Chrome Plated Exhaust Stacks (Curved Top - Plain Inlet)

CS3572P	Curved & Deflected Chrome Stack 3½" x 72" (1800mm) Long - Plain Inlet	
4"		
CS4024P	Curved & Deflected Chrome Stack 4" x 24" (600mm) Long - Plain Inlet	
CS4036P	Curved & Deflected Chrome Stack 4" x 36" (900mm) Long - Plain Inlet	
CS4048P	Curved & Deflected Chrome Stack 4" x 48" (1200mm) Long - Plain Inlet	
CS4060P	Curved & Deflected Chrome Stack 4" x 60" (1500mm) Long - Plain Inlet	
CS4072P	Curved & Deflected Chrome Stack 4" x 72" (1800mm) Long - Plain Inlet	
4½"		
CS4524P	Curved & Deflected Chrome Stack 4½" x 24" (600mm) Long - Plain Inlet	
CS4536P	Curved & Deflected Chrome Stack 4½" x 36" (900mm) Long - Plain Inlet	
CS4548P	Curved & Deflected Chrome Stack 4½" x 48" (1200mm) Long - Plain Inlet	
CS4560P	Curved & Deflected Chrome Stack 4½" x 60" (1500mm) Long - Plain Inlet	
CS4572P	Curved & Deflected Chrome Stack 4½" x 72" (1800mm) Long - Plain Inlet	
5"		
CS5024P	Curved & Deflected Chrome Stack 5" x 24" (600mm) Long - Plain Inlet	
CS5036P	Curved & Deflected Chrome Stack 5" x 36" (900mm) Long - Plain Inlet	
CS5048P	Curved & Deflected Chrome Stack 5" x 48" (1200mm) Long - Plain Inlet	
CS5060P	Curved & Deflected Chrome Stack 5" x 60" (1500mm) Long - Plain Inlet	
CS5072P	Curved & Deflected Chrome Stack 5" x 72" (1800mm) Long - Plain Inlet	
6"		
CS6024P	Curved & Deflected Chrome Stack 6" x 24" (600mm) Long - Plain Inlet	
CS6036P	Curved & Deflected Chrome Stack 6" x 36" (900mm) Long - Plain Inlet	
CS6048P	Curved & Deflected Chrome Stack 6" x 48" (1200mm) Long - Plain Inlet	
CS6060P	Curved & Deflected Chrome Stack 6" x 60" (1500mm) Long - Plain Inlet	
CS6072P	Curved & Deflected Chrome Stack 6" x 72" (1800mm) Long - Plain Inlet	

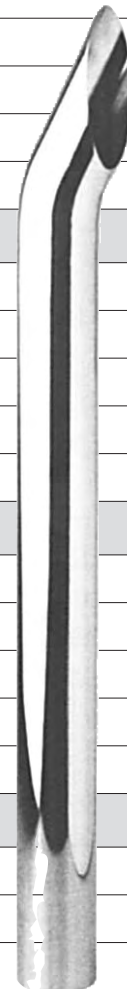

Chrome Plated Exhaust Stacks (Curved Top - Expanded & Notched Inlets)

2½"		
CS2524X	Curved & Deflected Chrome Stack 2½" x 24" (600mm) Long - Expanded Inlet	
CS2536X	Curved & Deflected Chrome Stack 2½" x 36" (900mm) Long - Expanded Inlet	
CS2548X	Curved & Deflected Chrome Stack 2½" x 48" (1200mm) Long - Expanded Inlet	
CS2560X	Curved & Deflected Chrome Stack 2½" x 60" (1500mm) Long - Expanded Inlet	
CS2572X	Curved & Deflected Chrome Stack 2½" x 72" (1800mm) Long - Expanded Inlet	
2¾"		
CS27524X	Curved & Deflected Chrome Stack 2¾" x 24" (600mm) Long - Expanded Inlet	
CS27536X	Curved & Deflected Chrome Stack 2¾" x 36" (900mm) Long - Expanded Inlet	
CS27548X	Curved & Deflected Chrome Stack 2¾" x 48" (1200mm) Long - Expanded Inlet	
CS27560X	Curved & Deflected Chrome Stack 2¾" x 60" (1500mm) Long - Expanded Inlet	
CS27572X	Curved & Deflected Chrome Stack 2¾" x 72" (1800mm) Long - Expanded Inlet	

CHROMEND SUPPLY CO. – TRUCK CATALOGUE 2007

Chrome Plated Exhaust Stacks (Curved Top - Expanded & Notched Inlets)		
3"		
CS3024X	Curved & Deflected Chrome Stack 3" x 24" (600mm) Long - Expanded Inlet	
CS3036X	Curved & Deflected Chrome Stack 3" x 36" (900mm) Long - Expanded Inlet	
CS3048X	Curved & Deflected Chrome Stack 3" x 48" (1200mm) Long - Expanded Inlet	
CS3060X	Curved & Deflected Chrome Stack 3" x 60" (1500mm) Long - Expanded Inlet	
CS3072X	Curved & Deflected Chrome Stack 3" x 72" (1800mm) Long - Expanded Inlet	
3 1/8"		
CS31824X	Curved & Deflected Chrome Stack 3 1/8" x 24" (600mm) Long - Expanded Inlet	
CS31836X	Curved & Deflected Chrome Stack 3 1/8" x 36" (900mm) Long - Expanded Inlet	
CS31848X	Curved & Deflected Chrome Stack 3 1/8" x 48" (1200mm) Long - Expanded Inlet	
CS31860X	Curved & Deflected Chrome Stack 3 1/8" x 60" (1500mm) Long - Expanded Inlet	
CS31872X	Curved & Deflected Chrome Stack 3 1/8" x 72" (1800mm) Long - Expanded Inlet	
Chrome Plated Exhaust Stacks (Curved Top - Expanded & Notched Inlet)		
3 1/2"		
CS3524X	Curved & Deflected Chrome Stack 3 1/2" x 24" (600mm) Long - Expanded Inlet	
CS3536X	Curved & Deflected Chrome Stack 3 1/2" x 36" (900mm) Long - Expanded Inlet	
CS3548X	Curved & Deflected Chrome Stack 3 1/2" x 48" (1200mm) Long - Expanded Inlet	
CS3560X	Curved & Deflected Chrome Stack 3 1/2" x 60" (1500mm) Long - Expanded Inlet	
CS3572X	Curved & Deflected Chrome Stack 3 1/2" x 72" (1800mm) Long - Expanded Inlet	
3 5/8"		
CS35824X	Curved & Deflected Chrome Stack 3 5/8" x 24" (600mm) Long - Expanded Inlet	
CS35836X	Curved & Deflected Chrome Stack 3 5/8" x 36" (900mm) Long - Expanded Inlet	
CS35848X	Curved & Deflected Chrome Stack 3 5/8" x 48" (1200mm) Long - Expanded Inlet	
CS35860X	Curved & Deflected Chrome Stack 3 5/8" x 60" (1500mm) Long - Expanded Inlet	
CS35872X	Curved & Deflected Chrome Stack 3 5/8" x 72" (1800mm) Long - Expanded Inlet	
4"		
CS4024X	Curved & Deflected Chrome Stack 4" x 24" (600mm) Long - Expanded Inlet	
CS4036X	Curved & Deflected Chrome Stack 4" x 36" (900mm) Long - Expanded Inlet	
CS4048X	Curved & Deflected Chrome Stack 4" x 48" (1200mm) Long - Expanded Inlet	
CS4060X	Curved & Deflected Chrome Stack 4" x 60" (1500mm) Long - Expanded Inlet	
CS4072X	Curved & Deflected Chrome Stack 4" x 72" (1800mm) Long - Expanded Inlet	
4 1/2"		
CS4524X	Curved & Deflected Chrome Stack 4 1/2" x 24" (600mm) Long - Expanded Inlet	
CS4536X	Curved & Deflected Chrome Stack 4 1/2" x 36" (900mm) Long - Expanded Inlet	
CS4548X	Curved & Deflected Chrome Stack 4 1/2" x 48" (1200mm) Long - Expanded Inlet	
CS4560X	Curved & Deflected Chrome Stack 4 1/2" x 60" (1500mm) Long - Expanded Inlet	
CS4572X	Curved & Deflected Chrome Stack 4 1/2" x 72" (1800mm) Long - Expanded Inlet	



CHROMEND SUPPLY CO. – TRUCK CATALOGUE 2007

Chrome Plated Exhaust Stacks (Curved Top - Expanded & Notched Inlet)

5"	
CS5024X	Curved & Deflected Chrome Stack 5" x 24" (600mm) Long - Expanded Inlet
CS5036X	Curved & Deflected Chrome Stack 5" x 36" (900mm) Long - Expanded Inlet
CS5048X	Curved & Deflected Chrome Stack 5" x 48" (1200mm) Long - Expanded Inlet
CS5060X	Curved & Deflected Chrome Stack 5" x 60" (1500mm) Long - Expanded Inlet
CS5072X	Curved & Deflected Chrome Stack 5" x 72" (1800mm) Long - Expanded Inlet

6"	
CS6024X	Curved & Deflected Chrome Stack 6" x 24" (600mm) Long - Expanded Inlet
CS6036X	Curved & Deflected Chrome Stack 6" x 36" (900mm) Long - Expanded Inlet
CS6048X	Curved & Deflected Chrome Stack 6" x 48" (1200mm) Long - Expanded Inlet
CS6060X	Curved & Deflected Chrome Stack 6" x 60" (1500mm) Long - Expanded Inlet
CS6072X	Curved & Deflected Chrome Stack 6" x 72" (1800mm) Long - Expanded Inlet

Chrome Plated Exhaust Stacks (Straight Top - Plain Inlets)

2½"	
SS2524P	Straight Stack 2½" x 24" (600mm) Long - Plain Inlet
SS2536P	Straight Stack 2½" x 36" (900mm) Long - Plain Inlet
SS2548P	Straight Stack 2½" x 48" (1200mm) Long - Plain Inlet
SS2560P	Straight Stack 2½" x 60" (1500mm) Long - Plain Inlet
SS2572P	Straight Stack 2½" x 72" (1800mm) Long - Plain Inlet

3"	
SS3024P	Straight Stack 3" x 24" (600mm) Long - Plain Inlet
SS3036P	Straight Stack 3" x 36" (900mm) Long - Plain Inlet
SS3048P	Straight Stack 3" x 48" (1200mm) Long - Plain Inlet
SS3060P	Straight Stack 3" x 60" (1500mm) Long - Plain Inlet
SS3072P	Straight Stack 3" x 72" (1800mm) Long - Plain Inlet

3½"	
SS3524P	Straight Stack 3½" x 24" (600mm) Long - Plain Inlet
SS3536P	Straight Stack 3½" x 36" (900mm) Long - Plain Inlet
SS3548P	Straight Stack 3½" x 48" (1200mm) Long - Plain Inlet
SS3560P	Straight Stack 3½" x 60" (1500mm) Long - Plain Inlet
SS3572P	Straight Stack 3½" x 72" (1800mm) Long - Plain Inlet

4"	
SS4024P	Straight Stack 4" x 24" (600mm) Long - Plain Inlet
SS4036P	Straight Stack 4" x 36" (900mm) Long - Plain Inlet
SS4048P	Straight Stack 4" x 48" (1200mm) Long - Plain Inlet
SS4060P	Straight Stack 4" x 60" (1500mm) Long - Plain Inlet
SS4072P	Straight Stack 4" x 72" (1800mm) Long - Plain Inlet



CHROMEND SUPPLY CO. – TRUCK CATALOGUE 2007

Chrome Plated Exhaust Stacks (Straight Top - Plain Inlets)

4½"	
SS4524P	Straight Stack 4½" x 24" (600mm) Long - Plain Inlet
SS4536P	Straight Stack 4½" x 36" (900mm) Long - Plain Inlet
SS4548P	Straight Stack 4½" x 48" (1200mm) Long - Plain Inlet
SS4560P	Straight Stack 4½" x 60" (1500mm) Long - Plain Inlet
SS4572P	Straight Stack 4½" x 72" (1800mm) Long - Plain Inlet
5"	
SS5024P	Straight Stack 5" x 24" (600mm) Long - Plain Inlet
SS5036P	Straight Stack 5" x 36" (900mm) Long - Plain Inlet
SS5048P	Straight Stack 5" x 48" (1200mm) Long - Plain Inlet
SS5060P	Straight Stack 5" x 60" (1500mm) Long - Plain Inlet
SS5072P	Straight Stack 5" x 72" (1800mm) Long - Plain Inlet
6"	
SS6024P	Straight Stack 6" x 24" (600mm) Long - Plain Inlet
SS6036P	Straight Stack 6" x 36" (900mm) Long - Plain Inlet
SS6048P	Straight Stack 6" x 48" (1200mm) Long - Plain Inlet
SS6060P	Straight Stack 6" x 60" (1500mm) Long - Plain Inlet
SS6072P	Straight Stack 6" x 72" (1800mm) Long - Plain Inlet

Chrome Plated Exhaust Stacks (Straight Top - Expanded & Notched Inlets)

2½"	
SS2524X	Straight Stack 2½" x 24" (600mm) Long - Expanded Inlet
SS2536X	Straight Stack 2½" x 36" (900mm) Long - Expanded Inlet
SS2548X	Straight Stack 2½" x 48" (1200mm) Long - Expanded Inlet
SS2560X	Straight Stack 2½" x 60" (1500mm) Long - Expanded Inlet
SS2572X	Straight Stack 2½" x 72" (1800mm) Long - Expanded Inlet
3"	
SS3024X	Straight Stack 3" x 24" (600mm) Long - Expanded Inlet
SS3036X	Straight Stack 3" x 36" (900mm) Long - Expanded Inlet
SS3048X	Straight Stack 3" x 48" (1200mm) Long - Expanded Inlet
SS3060X	Straight Stack 3" x 60" (1500mm) Long - Expanded Inlet
SS3072X	Straight Stack 3" x 72" (1800mm) Long - Expanded Inlet
3½"	
SS3524X	Straight Stack 3½" x 24" (600mm) Long - Expanded Inlet
SS3536X	Straight Stack 3½" x 36" (900mm) Long - Expanded Inlet
SS3548X	Straight Stack 3½" x 48" (1200mm) Long - Expanded Inlet
SS3560X	Straight Stack 3½" x 60" (1500mm) Long - Expanded Inlet
SS3572X	Straight Stack 3½" x 72" (1800mm) Long - Expanded Inlet



CHROMEND SUPPLY CO. – TRUCK CATALOGUE 2007

Chrome Plated Exhaust Stacks (Straight Top - Expanded & Notched Inlets)

4"	
SS4024X	Straight Stack 4" x 24" (600mm) Long - Expanded Inlet
SS4036X	Straight Stack 4" x 36" (900mm) Long - Expanded Inlet
SS4048X	Straight Stack 4" x 48" (1200mm) Long - Expanded Inlet
SS4060X	Straight Stack 4" x 60" (1500mm) Long - Expanded Inlet
SS4072X	Straight Stack 4" x 72" (1800mm) Long - Expanded Inlet
4½"	
SS4524X	Straight Stack 4½" x 24" (600mm) Long - Expanded Inlet
SS4536X	Straight Stack 4½" x 36" (900mm) Long - Expanded Inlet
SS4548X	Straight Stack 4½" x 48" (1200mm) Long - Expanded Inlet
SS4560X	Straight Stack 4½" x 60" (1500mm) Long - Expanded Inlet
SS4572X	Straight Stack 4½" x 72" (1800mm) Long - Expanded Inlet
5"	
SS5024X	Straight Stack 5" x 24" (600mm) Long - Expanded Inlet
SS5036X	Straight Stack 5" x 36" (900mm) Long - Expanded Inlet
SS5048X	Straight Stack 5" x 48" (1200mm) Long - Expanded Inlet
SS5060X	Straight Stack 5" x 60" (1500mm) Long - Expanded Inlet
SS5072X	Straight Stack 5" x 72" (1800mm) Long - Expanded Inlet
6"	
SS6024X	Straight Stack 6" x 24" (600mm) Long - Expanded Inlet
SS6036X	Straight Stack 6" x 36" (900mm) Long - Expanded Inlet
SS6048X	Straight Stack 6" x 48" (1200mm) Long - Expanded Inlet
SS6060X	Straight Stack 6" x 60" (1500mm) Long - Expanded Inlet
SS6072X	Straight Stack 6" x 72" (1800mm) Long - Expanded Inlet









45° Mitre Cut Stacks - Chrome Plated - Plain Inlet

5"	
MS5036P	Mitre Cut 45° Chrome Stack 5" x 36" (900mm) Long - Plain Inlet
MS5048P	Mitre Cut 45° Chrome Stack 5" x 48" (1200mm) Long - Plain Inlet
MS5060P	Mitre Cut 45° Chrome Stack 5" x 60" (1500mm) Long - Plain Inlet
MS5072P	Mitre Cut 45° Chrome Stack 5" x 72" (1800mm) Long - Plain Inlet
6"	
MS6036P	Mitre Cut 45° Chrome Stack 6" x 36" (900mm) Long - Plain Inlet
MS6048P	Mitre Cut 45° Chrome Stack 6" x 48" (1200mm) Long - Plain Inlet
MS6060P	Mitre Cut 45° Chrome Stack 6" x 60" (1500mm) Long - Plain Inlet
MS6072P	Mitre Cut 45° Chrome Stack 6" x 72" (1800mm) Long - Plain Inlet



CHROMEND SUPPLY CO. – TRUCK CATALOGUE 2007

Super Stacks - Chrome Plated With Reduced Inlets		
Deflector Style - 5" Reduced to 4" - Plain Inlet		
CRS5436P	Curved & Deflected Chrome Stack 5" Reduced to 4" x 36" (900mm) Long - Plain Inlet	
CRS5448P	Curved & Deflected Chrome Stack 5" Reduced to 4" x 48" (1200mm) Long - Plain Inlet	
CRS5460P	Curved & Deflected Chrome Stack 5" Reduced to 4" x 60" (1500mm) Long - Plain Inlet	
CRS5472P	Curved & Deflected Chrome Stack 5" Reduced to 4" x 72" (1800mm) Long - Plain Inlet	
Deflector Style - 6" Reduced to 5" - Plain Inlet		
CRS6524P	Curved & Deflected Chrome Stack 6" Reduced to 5" x 24" (600mm) Long - Plain Inlet	
CRS6536P	Curved & Deflected Chrome Stack 6" Reduced to 5" x 36" (900mm) Long - Plain Inlet	
CRS6548P	Curved & Deflected Chrome Stack 6" Reduced to 5" x 48" (1200mm) Long - Plain Inlet	
CRS6560P	Curved & Deflected Chrome Stack 6" Reduced to 5" x 60" (1500mm) Long - Plain Inlet	
CRS6572P	Curved & Deflected Chrome Stack 6" Reduced to 5" x 72" (1800mm) Long - Plain Inlet	
Deflector Style - 5" Reduced to 4" - Expanded Inlet		
CRS5436X	Curved & Deflected Chrome Stack 5" Reduced to 4" x 36" (900mm) Long - Expanded Inlet	
CRS5448X	Curved & Deflected Chrome Stack 5" Reduced to 4" x 48" (1200mm) Long - Expanded Inlet	
CRS5460X	Curved & Deflected Chrome Stack 5" Reduced to 4" x 60" (1500mm) Long - Expanded Inlet	
CRS5472X	Curved & Deflected Chrome Stack 5" Reduced to 4" x 72" (1800mm) Long - Expanded Inlet	
Deflector Style - 6" Reduced to 5" - Expanded Inlet		
CRS6524X	Curved & Deflected Chrome Stack 6" Reduced to 5" x 24" (600mm) Long - Expanded Inlet	
CRS6536X	Curved & Deflected Chrome Stack 6" Reduced to 5" x 36" (900mm) Long - Expanded Inlet	
CRS6548X	Curved & Deflected Chrome Stack 6" Reduced to 5" x 48" (1200mm) Long - Expanded Inlet	
CRS6560X	Curved & Deflected Chrome Stack 6" Reduced to 5" x 60" (1500mm) Long - Expanded Inlet	
CRS6572X	Curved & Deflected Chrome Stack 6" Reduced to 5" x 72" (1800mm) Long - Expanded Inlet	
Straight Style - 5" Reduced to 4" - Plain Inlet		
SRS5436P	Straight Stack 5" Reduced to 4" x 36" (900mm) Long - Plain Inlet	
SRS5448P	Straight Stack 5" Reduced to 4" x 48" (1200mm) Long - Plain Inlet	
SRS5460P	Straight Stack 5" Reduced to 4" x 60" (1500mm) Long - Plain Inlet	
SRS5472P	Straight Stack 5" Reduced to 4" x 72" (1800mm) Long - Plain Inlet	
Straight Style - 6" Reduced to 5" - Plain Inlet		
SRS6536P	Straight Stack 6" Reduced to 5" x 36" (900mm) Long - Plain Inlet	
SRS6548P	Straight Stack 6" Reduced to 5" x 48" (1200mm) Long - Plain Inlet	
SRS6560P	Straight Stack 6" Reduced to 5" x 60" (1500mm) Long - Plain Inlet	
SRS6572P	Straight Stack 6" Reduced to 5" x 72" (1800mm) Long - Plain Inlet	
Straight Style - 5" Reduced to 4" - Expanded Inlet		
SRS5436X	Straight Stack 5" Reduced to 4" x 36" (900mm) Long - Expanded Inlet	
SRS5448X	Straight Stack 5" Reduced to 4" x 48" (1200mm) Long - Expanded Inlet	
SRS5460X	Straight Stack 5" Reduced to 4" x 60" (1500mm) Long - Expanded Inlet	
SRS5472X	Straight Stack 5" Reduced to 4" x 72" (1800mm) Long - Expanded Inlet	

CHROMEND SUPPLY CO. – TRUCK CATALOGUE 2007

Super Stacks - Chrome Plated With Reduced Inlets

Straight Style - 6" Reduced to 5" - Expanded Inlet

SRS6536X	Straight Stack 6" Reduced to 5" x 36" (900mm) Long - Expanded Inlet	
SRS6548X	Straight Stack 6" Reduced to 5" x 48" (1200mm) Long - Expanded Inlet	
SRS6560X	Straight Stack 6" Reduced to 5" x 60" (1500mm) Long - Expanded Inlet	
SRS6572X	Straight Stack 6" Reduced to 5" x 72" (1800mm) Long - Expanded Inlet	

45° Mitre Cut Style - Reduced Inlet - Plain Inlet

MCRS5436P	Mitre Cut 45° Stack 5" Reduced to 4" x 36" (900mm) Long - Plain Inlet	
MCRS5448P	Mitre Cut 45° Stack 5" Reduced to 4" x 48" (1200mm) Long - Plain Inlet	
MCRS5460P	Mitre Cut 45° Stack 5" Reduced to 4" x 60" (1500mm) Long - Plain Inlet	
MCRS5472P	Mitre Cut 45° Stack 5" Reduced to 4" x 72" (1800mm) Long - Plain Inlet	

45° Mitre Cut Style - 6" Reduced to 5" - Plain Inlet

MCRS6536P	Mitre Cut 45° Stack 6" Reduced to 5" x 36" (900mm) Long - Plain Inlet	
MCRS6548P	Mitre Cut 45° Stack 6" Reduced to 5" x 48" (1200mm) Long - Plain Inlet	
MCRS6560P	Mitre Cut 45° Stack 6" Reduced to 5" x 60" (1500mm) Long - Plain Inlet	
MCRS6572P	Mitre Cut 45° Stack 6" Reduced to 5" x 72" (1800mm) Long - Plain Inlet	

45° Mitre Cut Style - 5" Reduced to 4" - Expanded Inlet

MCRS5436X	Mitre Cut 45° Stack 5" Reduced to 4" x 36" (900mm) Long - Expanded Inlet	
MCRS5448X	Mitre Cut 45° Stack 5" Reduced to 4" x 48" (1200mm) Long - Expanded Inlet	
MCRS5460X	Mitre Cut 45° Stack 5" Reduced to 4" x 60" (1500mm) Long - Expanded Inlet	
MCRS5472X	Mitre Cut 45° Stack 5" Reduced to 4" x 72" (1800mm) Long - Expanded Inlet	

45° Mitre Cut Style - 6" Reduced to 5" - Expanded Inlet

MCRS6536X	Mitre Cut 45° Stack 6" Reduced to 5" x 36" (900mm) Long - Expanded Inlet	
MCRS6548X	Mitre Cut 45° Stack 6" Reduced to 5" x 48" (1200mm) Long - Expanded Inlet	
MCRS6560X	Mitre Cut 45° Stack 6" Reduced to 5" x 60" (1500mm) Long - Expanded Inlet	
MCRS6572X	Mitre Cut 45° Stack 6" Reduced to 5" x 72" (1800mm) Long - Expanded Inlet	

45° Mitre Cut Style - 7" Reduced to 5" - Plain Inlet

MCRS7524P	Mitre Cut 45° Stack 7" Reduced to 5" x 24" (600mm) Long - Plain Inlet	
MCRS7536P	Mitre Cut 45° Stack 7" Reduced to 5" x 36" (900mm) Long - Plain Inlet	
MCRS7548P	Mitre Cut 45° Stack 7" Reduced to 5" x 48" (1200mm) Long - Plain Inlet	
MCRS7560P	Mitre Cut 45° Stack 7" Reduced to 5" x 60" (1500mm) Long - Plain Inlet	
MCRS7572P	Mitre Cut 45° Stack 7" Reduced to 5" x 72" (1800mm) Long - Plain Inlet	

CHROMEND SUPPLY CO. – TRUCK CATALOGUE 2007

Aluminised Exhaust Stacks (Curved Top - Plain Inlets)

2½"		
CSA2524P	Curved & Deflected Aluminised Stack 2½" x 24" (600mm) Long - Plain Inlet	
CSA2536P	Curved & Deflected Aluminised Stack 2½" x 36" (900mm) Long - Plain Inlet	
CSA2548P	Curved & Deflected Aluminised Stack 2½" x 48" (1200mm) Long - Plain Inlet	
CSA2560P	Curved & Deflected Aluminised Stack 2½" x 60" (1500mm) Long - Plain Inlet	
CSA2572P	Curved & Deflected Aluminised Stack 2½" x 72" (1800mm) Long - Plain Inlet	
3"		
CSA3024P	Curved & Deflected Aluminised Stack 3" x 24" (600mm) Long - Plain Inlet	
CSA3036P	Curved & Deflected Aluminised Stack 3" x 36" (900mm) Long - Plain Inlet	
CSA3048P	Curved & Deflected Aluminised Stack 3" x 48" (1200mm) Long - Plain Inlet	
CSA3060P	Curved & Deflected Aluminised Stack 3" x 60" (1500mm) Long - Plain Inlet	
CSA3072P	Curved & Deflected Aluminised Stack 3" x 72" (1800mm) Long - Plain Inlet	
3½"		
CSA3524P	Curved & Deflected Aluminised Stack 3½" x 24" (600mm) Long - Plain Inlet	
CSA3536P	Curved & Deflected Aluminised Stack 3½" x 36" (900mm) Long - Plain Inlet	
CSA3548P	Curved & Deflected Aluminised Stack 3½" x 48" (1200mm) Long - Plain Inlet	
CSA3560P	Curved & Deflected Aluminised Stack 3½" x 60" (1500mm) Long - Plain Inlet	
CSA3572P	Curved & Deflected Aluminised Stack 3½" x 72" (1800mm) Long - Plain Inlet	
4"		
CSA4024P	Curved & Deflected Aluminised Stack 4" x 24" (600mm) Long - Plain Inlet	
CSA4036P	Curved & Deflected Aluminised Stack 4" x 36" (900mm) Long - Plain Inlet	
CSA4048P	Curved & Deflected Aluminised Stack 4" x 48" (1200mm) Long - Plain Inlet	
CSA4060P	Curved & Deflected Aluminised Stack 4" x 60" (1500mm) Long - Plain Inlet	
CSA4072P	Curved & Deflected Aluminised Stack 4" x 72" (1800mm) Long - Plain Inlet	
4½"		
CSA4524P	Curved & Deflected Aluminised Stack 4½" x 24" (600mm) Long - Plain Inlet	
CSA4536P	Curved & Deflected Aluminised Stack 4½" x 36" (900mm) Long - Plain Inlet	
CSA4548P	Curved & Deflected Aluminised Stack 4½" x 48" (1200mm) Long - Plain Inlet	
CSA4560P	Curved & Deflected Aluminised Stack 4½" x 60" (1500mm) Long - Plain Inlet	
CSA4572P	Curved & Deflected Aluminised Stack 4½" x 72" (1800mm) Long - Plain Inlet	
5"		
CSA5024P	Curved & Deflected Aluminised Stack 5" x 24" (600mm) Long - Plain Inlet	
CSA5036P	Curved & Deflected Aluminised Stack 5" x 36" (900mm) Long - Plain Inlet	
CSA5048P	Curved & Deflected Aluminised Stack 5" x 48" (1200mm) Long - Plain Inlet	
CSA5060P	Curved & Deflected Aluminised Stack 5" x 60" (1500mm) Long - Plain Inlet	
CSA5072P	Curved & Deflected Aluminised Stack 5" x 72" (1800mm) Long - Plain Inlet	



CHROMEND SUPPLY CO. – TRUCK CATALOGUE 2007

Aluminised Exhaust Stacks (Curved Top - Plain Inlets)

6"	
CSA6024P	Curved & Deflected Aluminised Stack 6" x 24" (600mm) Long - Plain Inlet
CSA6036P	Curved & Deflected Aluminised Stack 6" x 36" (900mm) Long - Plain Inlet
CSA6048P	Curved & Deflected Aluminised Stack 6" x 48" (1200mm) Long - Plain Inlet
CSA6060P	Curved & Deflected Aluminised Stack 6" x 60" (1500mm) Long - Plain Inlet
CSA6072P	Curved & Deflected Aluminised Stack 6" x 72" (1800mm) Long - Plain Inlet



Aluminised Exhaust Stacks (Curved Top - Expanded Inlets)

2½"	
CSA2524X	Curved & Deflected Aluminised Stack 2½" x 24" (600mm) Long - Expanded Inlet
CSA2536X	Curved & Deflected Aluminised Stack 2½" x 36" (900mm) Long - Expanded Inlet
CSA2548X	Curved & Deflected Aluminised Stack 2½" x 48" (1200mm) Long - Expanded Inlet
CSA2560X	Curved & Deflected Aluminised Stack 2½" x 60" (1500mm) Long - Expanded Inlet
CSA2572X	Curved & Deflected Aluminised Stack 2½" x 72" (1800mm) Long - Expanded Inlet

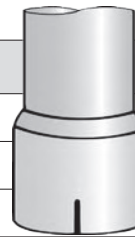

3"	
CSA3024X	Curved & Deflected Aluminised Stack 3" x 24" (600mm) Long - Expanded Inlet
CSA3036X	Curved & Deflected Aluminised Stack 3" x 36" (900mm) Long - Expanded Inlet
CSA3048X	Curved & Deflected Aluminised Stack 3" x 48" (1200mm) Long - Expanded Inlet
CSA3060X	Curved & Deflected Aluminised Stack 3" x 60" (1500mm) Long - Expanded Inlet
CSA3072X	Curved & Deflected Aluminised Stack 3" x 72" (1800mm) Long - Expanded Inlet

3½"	
CSA3524X	Curved & Deflected Aluminised Stack 3½" x 24" (600mm) Long - Expanded Inlet
CSA3536X	Curved & Deflected Aluminised Stack 3½" x 36" (900mm) Long - Expanded Inlet
CSA3548X	Curved & Deflected Aluminised Stack 3½" x 48" (1200mm) Long - Expanded Inlet
CSA3560X	Curved & Deflected Aluminised Stack 3½" x 60" (1500mm) Long - Expanded Inlet
CSA3572X	Curved & Deflected Aluminised Stack 3½" x 72" (1800mm) Long - Expanded Inlet

4"	
CSA4024X	Curved & Deflected Aluminised Stack 4" x 24" (600mm) Long - Expanded Inlet
CSA4036X	Curved & Deflected Aluminised Stack 4" x 36" (900mm) Long - Expanded Inlet
CSA4048X	Curved & Deflected Aluminised Stack 4" x 48" (1200mm) Long - Expanded Inlet
CSA4060X	Curved & Deflected Aluminised Stack 4" x 60" (1500mm) Long - Expanded Inlet
CSA4072X	Curved & Deflected Aluminised Stack 4" x 72" (1800mm) Long - Expanded Inlet

4½"	
CSA4524X	Curved & Deflected Aluminised Stack 4½" x 24" (600mm) Long - Expanded Inlet
CSA4536X	Curved & Deflected Aluminised Stack 4½" x 36" (900mm) Long - Expanded Inlet
CSA4548X	Curved & Deflected Aluminised Stack 4½" x 48" (1200mm) Long - Expanded Inlet
CSA4560X	Curved & Deflected Aluminised Stack 4½" x 60" (1500mm) Long - Expanded Inlet
CSA4572X	Curved & Deflected Aluminised Stack 4½" x 72" (1800mm) Long - Expanded Inlet

CHROMEND SUPPLY CO. – TRUCK CATALOGUE 2007

Aluminised Exhaust Stacks (Curved Top - Expanded Inlets)

5"	
CSA5024X	Curved & Deflected Aluminised Stack 5" x 24" (600mm) Long - Expanded Inlet
CSA5036X	Curved & Deflected Aluminised Stack 5" x 36" (900mm) Long - Expanded Inlet
CSA5048X	Curved & Deflected Aluminised Stack 5" x 48" (1200mm) Long - Expanded Inlet
CSA5060X	Curved & Deflected Aluminised Stack 5" x 60" (1500mm) Long - Expanded Inlet
CSA5072X	Curved & Deflected Aluminised Stack 5" x 72" (1800mm) Long - Expanded Inlet
6"	
CSA6024X	Curved & Deflected Aluminised Stack 6" x 24" (600mm) Long - Expanded Inlet
CSA6036X	Curved & Deflected Aluminised Stack 6" x 36" (900mm) Long - Expanded Inlet
CSA6048X	Curved & Deflected Aluminised Stack 6" x 48" (1200mm) Long - Expanded Inlet
CSA6060X	Curved & Deflected Aluminised Stack 6" x 60" (1500mm) Long - Expanded Inlet
CSA6072X	Curved & Deflected Aluminised Stack 6" x 72" (1800mm) Long - Expanded Inlet

Aluminised Silenced Stacks - Straight Top - Plain Inlet

4"	
ASS4045	Aluminised Straight Silenced Stack - 4" x 45" (1143mm) Long
5"	
ASS5045	Aluminised Straight Silenced Stack - 5" x 45" (1143mm) Long

Chrome Plated Silenced Stacks - Straight Top - Plain Inlet (Made to Order)

5"	
SS5036PAK-P	Chrome Straight Packed Stack 5" x 36" (900mm) Long - Plain Inlet
SS5048PAK-P	Chrome Straight Packed Stack 5" x 48" (1200mm) Long - Plain Inlet
6"	
SS6048PAK-P	Chrome Straight Packed Stack 6" x 48" (1200mm) Long - Plain Inlet
SS6060PAK-P	Chrome Straight Packed Stack 6" x 60" (1500mm) Long - Plain Inlet



Chrome Plated Silenced Stacks - Curved Top - Plain Inlet (Made to Order)

CS6048PAK-P	Curved & Deflected Chrome Packed Stack 6" x 48" (1200mm) Long - Plain Inlet
CS6060PAK-P	Curved & Deflected Chrome Packed Stack 6" x 60" (1500mm) Long - Plain Inlet

Galvanised Flexible Tubing (mm/inch) Polylock - Per Metre

GSF25	Galvanised Flexible Tubing 25mm (1") ID
GSF32	Galvanised Flexible Tubing 32mm (1¼") ID
GSF38	Galvanised Flexible Tubing 38mm (1½") ID
GSF41	Galvanised Flexible Tubing 41mm (1⅝") ID
GSF44	Galvanised Flexible Tubing 44mm (1¾") ID
GSF47	Galvanised Flexible Tubing 47mm (1⅞") ID
GSF51	Galvanised Flexible Tubing 51mm (2") ID
GSF57	Galvanised Flexible Tubing 57mm (2¼") ID
GSF63	Galvanised Flexible Tubing 63mm (2½") ID
GSF70	Galvanised Flexible Tubing 70mm (2¾") ID
GSF76	Galvanised Flexible Tubing 76mm (3") ID

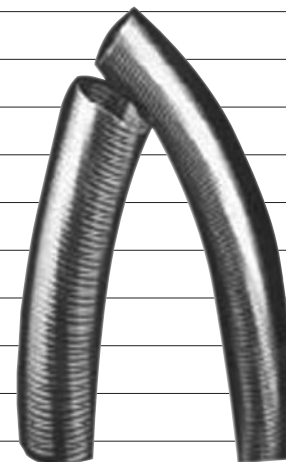

CHROMEND SUPPLY CO. – TRUCK CATALOGUE 2007

Galvanised Flexible Tubing (mm/inch) Polylock - Per Metre

GSF89	Galvanised Flexible Tubing 89mm (3½") ID	
GSF102	Galvanised Flexible Tubing 102mm (4") ID	
GSF114	Galvanised Flexible Tubing 114mm (4½") ID	
GSF127	Galvanised Flexible Tubing 127mm (5") ID	
GSF152	Galvanised Flexible Tubing 152mm (6") ID	

Stainless Steel Flexible Tubing (mm/inch) Polylock - Per Metre

SSF25	Stainless Steel Flexible Tubing 25mm (1") ID	
SSF32	Stainless Steel Flexible Tubing 32mm (1¼") ID	
SSF38	Stainless Steel Flexible Tubing 38mm (1½") ID	
SSF44	Stainless Steel Flexible Tubing 44mm (1¾") ID	
SSF51	Stainless Steel Flexible Tubing 51mm (2") ID	
SSF57	Stainless Steel Flexible Tubing 57mm (2¼") ID	
SSF63	Stainless Steel Flexible Tubing 63mm (2½") ID	
SSF70	Stainless Steel Flexible Tubing 70mm (2¾") ID	
SSF76	Stainless Steel Flexible Tubing 76mm (3") ID	
SSF89	Stainless Steel Flexible Tubing 89mm (3½") ID	
SSF102	Stainless Steel Flexible Tubing 102mm (4") ID	
SSF114	Stainless Steel Flexible Tubing 114mm (4½") ID	
SSF127	Stainless Steel Flexible Tubing 127mm (5") ID	
SSF152	Stainless Steel Flexible Tubing 152mm (6") ID	

Heavy Duty Stainless Steel Flexible Tubing (mm/inch) Extra Heavy Duty - Per Metre

HDSF152	Heavy Duty Stainless Steel Flexible Tubing 152mm (6") ID	
HDSF175	Heavy Duty Stainless Steel Flexible Tubing 175mm (7") ID	
HDSF203	Heavy Duty Stainless Steel Flexible Tubing 203mm (8") ID	
HDSF250	Heavy Duty Stainless Steel Flexible Tubing 250mm (10") ID	

Straight Tube - Mild Steel - Per Metre

ST25	Mild Steel Straight Tube - 25mm (1") OD - (Standard Length: 2 metres)	
ST32	Mild Steel Straight Tube - 32mm (1¼") OD - (Standard Length: 2 metres)	
ST35	Mild Steel Straight Tube - 35mm (1⅝") OD - (Standard Length: 2 metres)	
ST38	Mild Steel Straight Tube - 38mm (1½") OD - (Standard Length: 2 metres)	
ST42	Mild Steel Straight Tube - 42mm (1⅞") OD - (Standard Length: 2 metres)	
ST45	Mild Steel Straight Tube - 45mm (1¾") OD - (Standard Length: 2 metres)	
ST48	Mild Steel Straight Tube - 48mm (1⅞") OD - (Standard Length: 2 metres)	
ST51	Mild Steel Straight Tube - 51mm (2") OD - (Standard Length: 2 metres)	
ST54	Mild Steel Straight Tube - 54mm (2⅞") OD - (Standard Length: 2 metres)	
ST57	Mild Steel Straight Tube - 57mm (2¼") OD - (Standard Length: 2 metres)	
ST63	Mild Steel Straight Tube - 63mm (2½") OD - (Standard Length: 2 metres)	
ST70	Mild Steel Straight Tube - 70mm (2¾") OD - (Standard Length: 2 metres & 3 metres)	
ST76	Mild Steel Straight Tube - 76mm (3") OD - (Standard Length: 2 metres & 3 metres)	

CHROMEND SUPPLY CO. – TRUCK CATALOGUE 2007

Straight Tube - Mild Steel - Per Metre		
ST76-2.5	Mild Steel Straight Tube - 2½mm wall thickness x 76mm (3") OD - (Standard Length: 3 metres)	
ST89	Mild Steel Straight Tube - 89mm (3½") OD - (Standard Length: 1 metre, 2 metres, 3 metres)	
ST102	Mild Steel Straight Tube - 102mm (4") OD - (Standard Length: 1 metre, 2 metres, 3 metres)	
ST114	Mild Steel Straight Tube - 114mm (4½") OD - (Standard Length: 97cm, 1.94 metres, 2.92 metres)	
ST127	Mild Steel Straight Tube - 127mm (5") OD - (Standard Length: 1.94m, 2.92 metres)	
ST140	Mild Steel Straight Tube - 140mm (5½") OD - (Standard Length: 2.92 metres)	
ST152	Mild Steel Straight Tube - 152mm (6") OD - (Standard Length: 2.92 metres)	
ST178	Mild Steel Straight Tube - 178mm (7") OD - (Standard Length: 2.92 metres)	
ST203	Mild Steel Straight Tube - 203mm (8") OD - (Standard Length: 2.92 metres)	
ST254	Mild Steel Straight Tube - 254mm (10") OD - (Standard Length: 2.92 metres)	
Straight Tube - Aluminised - Per Metre		
AT38	Aluminised Straight Tube - 38mm (1½") OD	
AT41	Aluminised Straight Tube - 42mm (1⅝") OD	
AT45	Aluminised Straight Tube - 45mm (1¾") OD	
AT48	Aluminised Straight Tube - 48mm (1⅞") OD	
AT51	Aluminised Straight Tube - 51mm (2") OD	
AT57-2	Aluminised Straight Tube - 2mm wall thickness x 57mm (2¼") OD	
AT63-2	Aluminised Straight Tube - 2mm wall thickness x 63mm (2½") OD	
AT76	Aluminised Straight Tube - 76mm (3") OD	
AT76-2	Aluminised Straight Tube - 2mm wall thickness x 76mm (3") OD	
AT89	Aluminised Straight Tube - 89mm (3½") OD	
AT102	Aluminised Straight Tube - 102mm (4") OD	
AT114	Aluminised Straight Tube - 114mm (4½") OD - (Standard Length: 1.46 metres, 2.92 metres)	
AT127	Aluminised Straight Tube - 127mm (5") OD - (Standard Length: 1.46 metres, 2.92 metres)	
AT152	Aluminised Straight Tube - 152mm (6") OD - (Standard Length: 1.46 metres, 2.92 metres)	
AT203	Aluminised Straight Tube - 203mm (8") OD - (Standard Length: 1.46 metres, 2.92 metres)	
AT254	Aluminised Straight Tube - 254mm (10") OD - (Standard Length: 2.92 metres)	
Straight Tube - Stainless Steel (409 Grade) - Per Metre		
SST38-409	Stainless Steel Straight Tube (409 Grade) - 38mm (1½") OD	
SST41-409	Stainless Steel Straight Tube (409 Grade) - 42mm (1□") OD	
SST45-409	Stainless Steel Straight Tube (409 Grade) - 45mm (1¾") OD	
SST48-409	Stainless Steel Straight Tube (409 Grade) - 48mm !	
SST51-409	Stainless Steel Straight Tube (409 Grade) - 51mm (2") OD	
SST57-409	Stainless Steel Straight Tube (409 Grade) - 57mm (2¼") OD	
SST63-409	Stainless Steel Straight Tube (409 Grade) - 63mm (2½") OD	
** All S/S Tube Standard Length 2 Metres - special length available on request.		

CHROMEND SUPPLY CO. – TRUCK CATALOGUE 2007

Straight Tube - Stainless Steel (304 Grade) - Per Metre

SST25-304	Stainless Steel Straight Tube (304 Grade) - 25mm (1") OD - (2 metre lengths)	
SST32-304	Stainless Steel Straight Tube (304 Grade) - 32mm (1¼") OD (2 metre lengths)	
SST38-304	Stainless Steel Straight Tube (304 Grade) - 38mm (1½") OD (2 metre lengths)	
SST45-304	Stainless Steel Straight Tube (304 Grade) - 45mm (1¾") OD (2 metre lengths)	
SST48-304	Stainless Steel Straight Tube (304 Grade) - 48mm (1⅞") OD (2 metre lengths)	
SST51-304	Stainless Steel Straight Tube (304 Grade) - 51mm (2") OD (2 metre lengths)	
SST57-304	Stainless Steel Straight Tube (304 Grade) - 57mm (2¼") OD (2 metre lengths)	
SST63-304	Stainless Steel Straight Tube (304 Grade) - 63mm (2½") OD (2 metre lengths)	
SST76-304	Stainless Steel Straight Tube (304 Grade) - 76mm (3") OD	
SST89-304	Stainless Steel Straight Tube (304 Grade) - 89mm (3½") OD	
SST102-304	Stainless Steel Straight Tube (304 Grade) - 102mm (4") OD	
SST127-304	Stainless Steel Straight Tube (304 Grade) - 127mm (5") OD	
SST152-304	Stainless Steel Straight Tube (304 Grade) - 152mm (6") OD	

Straight Tube - Stainless Steel (316 Grade) - Per Metre

SST32-316	Stainless Steel Straight Tube (316 Grade) - 32mm (1¼") OD	
SST38-316	Stainless Steel Straight Tube (316 Grade) - 38mm (1½") OD	
SST45-316	Stainless Steel Straight Tube (316 Grade) - 45mm (1¾") OD	
SST51-316	Stainless Steel Straight Tube (316 Grade) - 51mm (2") OD	
SST57-316	Stainless Steel Straight Tube (316 Grade) - 57mm (2¼") OD	
SST63-316	Stainless Steel Straight Tube (316 Grade) - 63mm (2½") OD	
SST76-316	Stainless Steel Straight Tube (316 Grade) - 76mm (3") OD	
SST89-316	Stainless Steel Straight Tube (316 Grade) - 89mm (3½") OD	
SST102-316	Stainless Steel Straight Tube (316 Grade) - 102mm (4") OD	
SST127-316	Stainless Steel Straight Tube (316 Grade) - 127mm (5") OD	
SST152-316	Stainless Steel Straight Tube (316 Grade) - 152mm (6") OD	

Straight Tube - Aluminium (Lightweight Air) - Per Metre

ALT51	Aluminium Straight Tube (Lightweight - Air) 51mm (2") OD	
ALT57	Aluminium Straight Tube (Lightweight - Air) 57mm (2¼") OD	
ALT63	Aluminium Straight Tube (Lightweight - Air) 63mm (2½") OD	
ALT76	Aluminium Straight Tube (Lightweight - Air) 76mm (3") OD	
ALT102	Aluminium Straight Tube (Lightweight - Air) 102mm (4") OD	
ALT127	Aluminium Straight Tube (Lightweight - Air) 127mm (5") OD - (Standard Length: 3 metres)	
ALT152	Aluminium Straight Tube (Lightweight - Air) 152mm (6") OD - (Standard Length: 2.92 metres)	
ALT178	Aluminium Straight Tube (Lightweight - Air) 178mm (7") OD - (Standard Length: 2.92 metres)	
ALT203	Aluminium Straight Tube (Lightweight - Air) 203mm (8") OD - (Standard Length: 2.92 metres)	

Heavy Duty Tube (Steam Pipe) (3.2mm Wall) (ID Measurement) - Per Metre

HDT125	Heavy Duty Steam Pipe Tube - 3.2mm wall thickness - 32mm (1¼") ID	
HDT150	Heavy Duty Steam Pipe Tube - 3.2mm wall thickness - 38mm (1½") ID	
HDT200	Heavy Duty Steam Pipe Tube - 3.2mm wall thickness - 51mm (2") ID	
HDT250	Heavy Duty Steam Pipe Tube - 3.2mm wall thickness - 63mm (2½") ID	

CHROMEND SUPPLY CO. – TRUCK CATALOGUE 2007

Heavy Duty Tube (Steam Pipe) (3.2mm Wall) (ID Measurement) - Per Metre	
HDT300	Heavy Duty Steam Pipe Tube - 3.2mm wall thickness - 76mm (3") ID
Aluminised Perforated Tube - Per Metre	
ASPERF-125	Aluminised Perforated Tube - 32mm (1¼") OD
ASPERF-150	Aluminised Perforated Tube - 38mm (1½") OD
ASPERF-175	Aluminised Perforated Tube - 45mm (1¾") OD
ASPERF-200	Aluminised Perforated Tube - 51mm (2") OD
ASPERF-225	Aluminised Perforated Tube - 57mm (2¼") OD
ASPERF-250	Aluminised Perforated Tube - 63mm (2½") OD
ASPERF-300	Aluminised Perforated Tube - 76mm (3") OD
Rolled Perforated Tube - Per Metre	
MSPERF-350	Mild Steel Perforated Tube - 89mm (3½") OD
MSPERF-400	Mild Steel Perforated Tube - 102mm (4") OD
MSPERF-450	Mild Steel Perforated Tube - 114mm (4½") OD
MSPERF-500	Mild Steel Perforated Tube - 127mm (5") OD
Stainless Steel Perforated Tube - Per Metre	
SSPERF-150	Stainless Steel Perforated Tube - 38mm (1½") OD
SSPERF-175	Stainless Steel Perforated Tube - 45mm (1¾") OD
SSPERF-200	Stainless Steel Perforated Tube - 51mm (2") OD
SSPERF-250	Stainless Steel Perforated Tube - 63mm (2½") OD
SSPERF-300	Stainless Steel Perforated Tube - 76mm (3") OD
Polished Stainless Steel - Flame Proof Pipe Shrouds	
Short Kit: one transition cap, two shrouds, one connect ring, one mounting ring/bracket, one set of pipe support brackets	
0134TSS076	Polished Stainless Steel (Short Kit) - 76mm (3") - 203mm diameter x 1540mm Length
0134TSS102	Polished Stainless Steel (Short Kit) - 102mm (4") - 203mm diameter x 1540mm Length
0134TSS114	Polished Stainless Steel (Short Kit) - 114mm (4½") - 229mm diameter x 1540mm Length
0134TSS127	Polished Stainless Steel (Short Kit) - 127mm (5") - 203mm diameter x 1540mm Length
Long Kit: one transition cap, three shrouds, two connect rings, one mounting ring/bracket, three sets of pipe support brackets	
0134TSL076	Polished Stainless Steel (Long Kit) - 76mm (3") - 203mm diameter x 2290mm Length
0134TSL102	Polished Stainless Steel (Long Kit) - 102mm (4") - 203mm diameter x 2290mm Length
0134TSL114	Polished Stainless Steel (Long Kit) - 114mm (4½") - 203mm diameter x 2290mm Length
0134TSL127	Polished Stainless Steel (Long Kit) - 127mm (5") - 203mm diameter x 2290mm Length
Stainless Steel Tanker Kit & Pipe Shroud - Spare Parts	
Transition Caps - Small: suits top of tanker kit or pipe shroud	
0134TCS076	Transition cap (small) - 76mm (3") (203mm x 76mm) OD x ID
0134TCS089	Transition cap (small) - 89mm (3½") (203mm x 89mm) OD x ID
0134TCS102	Transition cap (small) - 102mm (4") (203mm x 102mm) OD x ID
0134TCS114	Transition cap (small) - 114mm (4½") (229mm x 114mm) OD x ID
0134TCS127	Transition cap (small) - 127mm (5") (229mm x 127mm) OD x ID



CHROMEND SUPPLY CO. – TRUCK CATALOGUE 2007

Stainless Steel Tanker Kit & Pipe Shroud - Spare Parts

Transition Caps - Large: suits top of the bottom shroud

0134TCL076	Transition cap (large) - 76mm (3") (305mm x 203mm) OD x ID	
0134TCL089	Transition cap (large) - 89mm (3½") (356mm x 203mm) OD x ID	
0134TCL102	Transition cap (large) - 102mm (4") (356mm x 203mm) OD x ID	
0134TCL114	Transition cap (large) - 114mm (4½") (356mm x 203mm) OD x ID	
0134TCL127	Transition cap (large) - 127mm (5") (356mm x 203mm) OD x ID	

Tanker Kit Bracket Mounting Rings

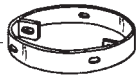
FGMR12	Mounting ring to suit guard diameter x 305mm (12")	
FGMR14	Mounting ring to suit guard diameter x 356mm (14")	

Pipe Shroud Connect Rings - joins pipe shrouds sections in pipe shrouds kits

PSR08	Pipe Shroud Connect Ring - suit kit size 76mm-102mm (3-4") - Guard Diameter 203mm	
PSR09	Pipe Shroud Connect Ring - suit kit size 114mm-127mm (4½"-5") - Guard Diameter 203mm	

Shrouds - Top Shrouds - with or without top transition cap

0134TST076	Top Shroud - 76mm (3")	
0134TST076C	Top Shroud - 76mm (3") - with transition cap	
0134TST089	Top Shroud - 89mm (3½")	
0134TST102	Top Shroud - 102mm (4")	
0134TST102C	Top Shroud - 102mm (4") - with transition cap	
0134TST114	Top Shroud - 114mm (4½")	
0134TST114C	Top Shroud - 114mm (4½") - with transition cap	
0134TST127	Top Shroud - 127mm (5")	
0134TST127C	Top Shroud - 127mm (5") - with transition cap	

Shrouds - Bottom Shrouds

0134TSB076	Bottom Shroud - 76mm (3")	
0134TSB089	Bottom Shroud - 89mm (3½")	
0134TSB102	Bottom Shroud - 102mm (4")	
0134TSB102C	Bottom Shroud - 102mm (4") - with transition cap	
0134TSB114	Bottom Shroud - 114mm (4½")	
0134TSB114C	Bottom Shroud - 114mm (4½") - with transition cap	
0134TSB127	Bottom Shroud - 127mm (5")	
0134TSB127C	Bottom Shroud - 127mm (5") - with transition cap	
TKBS356L	Tanker Kit Bottom Shroud - 127mm (5") (1500mm)	

Muffler Support Brackets - Zinc Plated

0134GB076E	Muffler Support Brackets - 76mm (3") - suit 76mm pipe size x 305mm bottom shroud diameter	
0134GB089F	Muffler Support Brackets - 89mm (3½") - suit 89mm pipe size x 356mm bottom shroud diameter	
0134GB102F	Muffler Support Brackets - 102mm (4") - suit 102mm pipe size x 356mm bottom shroud diameter	
0134GB114D	Muffler Support Brackets - 114mm (4½") - suit 114mm pipe size x 229mm bottom shroud diameter	
0134GB114F	Muffler Support Brackets - 114mm (4½") - suit 114mm pipe size x 356mm bottom shroud diameter	
0134GB127D	Muffler Support Brackets - 127mm (5") - suit 127mm pipe size x 229mm bottom shroud diameter	

CHROMEND SUPPLY CO. – TRUCK CATALOGUE 2007

Flame Proof Tanker Kits - Designed to Australian Standard AS2016 - Complete Kit

Flame 300	3" (76mm) Kit: Top & Bottom Shrouds, T/Cap, Muffler Brackets, Straight Stack & Raincap	
Flame 350	3½" (89mm) Kit: Top & Bottom Shrouds, T/Cap, Muffler Brackets, Straight Stack & Raincap	
Flame 400	4" (102mm) Kit: Top & Bottom Shrouds, T/Cap, Muffler Brackets, Straight Stack & Raincap	
Flame 450	4½" (114mm) Kit: Top & Bottom Shrouds, T/Cap, Muffler Brackets, Straight Stack & Raincap	
Flame 500	5" (127mm) Kit: Top & Bottom Shrouds, T/Cap, Muffler Brackets, Straight Stack & Raincap	
Flame 500D	5" (127mm) Kit: Top & Bottom Shrouds, T/Cap, Muffler Brackets, Curved Stack	
Flame 500LV	5" (127mm) Kit: Top & Bottom Shrouds, T/Cap, Muffler Brackets, Straight Stack & Raincap	

Clamp Kits - Double Plated Chrome

Half Guards

SPGB400	4" ID x 5¼" OD Half Guard Clamp Kit (To suit guard no. SPGH648)
SPGB500	5" ID x 6¼" OD Half Guard Clamp Kit (To suit guard no. SPGH648)
SPGB600	6" ID x 7¾" OD Half Guard Clamp Kit (To suit guard no. SPGH848)
SPGB850	8½" ID x 10¼" OD Half Guard Clamp Kit (To suit guard no. GH1248-8510S)
SPGB9180	9" ID x 10¾" OD Half Guard Clamp Kit (To suit guard no. GH1248-8510S)
SPGB1012H	10.12" ID x 11.85" OD Half Guard Clamp Kit (To suit guard no. GH1248-8510S)

Three-Quarter Guards

SPGB900F	9" ID x 10¾" OD Three-Quarter Guard Clamp Kit (To suit guard GF1248-8510S & GF1251-8510S)
SPGB1034F	10.12" ID x 11.85" OD Three-Quarter Guard Clamp Kit (To suit guard GF1248-8510S & GF1251-8510S)

180° Half Muffler Guards - Stainless Steel (For 8", 10" & 12" Guard refer GB Brackets - next page)

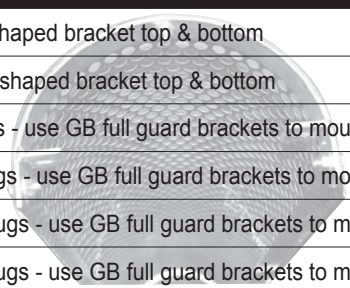
GH636	S/S Half Muffler Guard 6" (152mm) x 36" (915mm) - has D shaped bracket top & bottom	
GH648	S/S Half Muffler Guard 6" (152mm) x 48" (1220mm) - has D shaped bracket top & bottom	
GH836	S/S Half Muffler Guard 8" (203mm) x 36" (915mm) - has lugs - use GB full guard brackets to mount	
GH848	S/S Half Muffler Guard 8" (203mm) x 48" (1220mm) - has lugs - use GB full guard brackets to mount	
GH1048	S/S Half Muffler Guard 10" (254mm) x 48" (1220mm) - has lugs - use GB full guard brackets to mount	
GH1248	S/S Half Muffler Guard 12" (305mm) x 48" (1220mm) - has lugs - use GB full guard brackets to mount	

Heat Guards - Universal - Stainless Steel

SPGH348	S/S Half Guard Wrap - suits 1½" up to 3" Pipe (38mm to 76mm) x 48" Long (1220mm)
SPGH648	S/S Half Guard Wrap - suits 4" up to 5" Pipe (102mm to 127mm) x 48" Long (1220mm)
SPGH848	S/S Half Guard Wrap - suits 6" Pipe (152mm) x 48" Long (1220mm)
GH1248-8510S	S/S Half Guard Wrap - suits 8½" - 10½" Muffler (216mm to 266mm) x 48" Long (1220mm)
GF1248-8510S	S/S Three-Quarter Guard Wrap - suits 8½"-10½" Muffler (216mm to 266mm) x 48" Long (1220mm)
GF1251-8510S	S/S Three-Quarter Guard Wrap - suits 8½"-10½" Muffler (216mm to 266mm) x 51" Long (1295mm)

Channel Mount Pipe Guards

SPGH348CM	Channel Mount S/S Half Guard Wrap - suits 1½" up to 3" Pipe (38mm to 76mm) x 48" Long (1220mm)
------------------	--

360° Full Muffler Guards - Polished Stainless Steel

GF636	S/S Full Muffler Guard 6" (152mm) x 36" (915mm)
GF648	S/S Full Muffler Guard 6" (152mm) x 48" (1220mm)
GF836	S/S Full Muffler Guard 8" (203mm) x 36" (915mm)
GF848	S/S Full Muffler Guard 8" (203mm) x 48" (1220mm)

CHROMEND SUPPLY CO. – TRUCK CATALOGUE 2007

Mufflers - Centre-Centre (Free Flow)

6" Barrel		
M620-250	Flowtech - 6" body diameter x 20" body length - 2½" in/out - straight through	
M620-300	Flowtech - 6" body diameter x 20" body length - 3" in/out - straight through	
MRB624-200	Mid-range - 6" body diameter x 24" body length - 2" in/out - baffled	
MR624-200E	Mid-range - 6" body diameter x 24" body length - 2" in/out - straight through	
MRB624-225	Mid-range - 6" body diameter x 24" body length - 2¼" in/out - baffled	
MR624-225E	Mid-range - 6" body diameter x 24" body length - 2¼" in/out - straight through	
MR624-250E	Mid-range - 6" body diameter x 24" body length - 2½" in/out - straight through	
MR624-300E	Mid-range - 6" body diameter x 24" body length - 3" in/out - straight through	
MR624-350E	Mid-range - 6" body diameter x 24" body length - 3½" in/out - straight through	
MR624-400	Flowtech - 6" body diameter x 24" body length - 4" in/out - straight through	
MR630-225E	Mid-range - 6" body diameter x 30" body length - 2¼" in/out - straight through	
MR630-250E	Mid-range - 6" body diameter x 30" body length - 2½" in/out - straight through	
MR630-300E	Mid-range - 6" body diameter x 30" body length - 3" in/out - straight through	
MR630-350E	Mid-range - 6" body diameter x 30" body length - 3½" in/out - straight through	
M630-400	Flowtech - 6" body diameter x 30" body length - 4" in/out - straight through	
MR636-250E	Mid-range - 6" body diameter x 36" body length - 2½" in/out - straight through	
MR636-300E	Mid-range - 6" body diameter x 36" body length - 3" in/out - straight through	
M640-350	Flowtech - 6" body diameter x 40" body length - 3½" in/out - straight through	
M640-400	Flowtech - 6" body diameter x 40" body length - 4" in/out - straight through	
M655-400	Flowtech - 6" body diameter x 55" body length - 4" in/out - straight through - suits Acco	
7" Barrel		
M716-250	Flowtech - 7" body diameter x 16" body length - 2½" in/out - straight through	
M716-300	Flowtech - 7" body diameter x 16" body length - 3" in/out - straight through	
M716-350	Flowtech - 7" body diameter x 16" body length - 3½" in/out - straight through	
M716-400	Flowtech - 7" body diameter x 16" body length - 4" in/out - straight through	
M720-250	Flowtech - 7" body diameter x 20" body length - 2½" in/out - straight through	
M720-300	Flowtech - 7" body diameter x 20" body length - 3" in/out - straight through	
MB722-23856	Flowtech - 7" body diameter x 22" body length - 60mm in / 56mm out - baffled	
MR724-225E	Mid-range - 7" body diameter x 24" body length - 2¼" in/out - straight through	
MR724-250E	Mid-range - 7" body diameter x 24" body length - 2½" in/out - straight through	
MRB724-250	Mid-range - 7" body diameter x 24" body length - 2½" in/out - baffled	
MR724-300E	Mid-range - 7" body diameter x 24" body length - 3" in/out - straight through	
MRB724-300	Mid-range - 7" body diameter x 24" body length - 3" in/out - baffled	
M724-300	Flowtech - 7" body diameter x 24" body length - 3" in/out - straight through	
MR724-350E	Mid-range - 7" body diameter x 24" body length - 3½" in/out - straight through	
MB726-2F51	Flowtech - 7" body dia. x 26" body length - 2 bolt flange inlet x 2" ID out - baffled - suits Isuzu	
MB726-2FI	Flowtech - 7" body dia. x 26" body length - 2 b/flange in/out (both ends) - baffled - suits Isuzu	
M728-400	Flowtech - 7" body diameter x 28" body length - 4" in/out - straight through	



CHROMEND SUPPLY CO. – TRUCK CATALOGUE 2007

Mufflers - Centre-Centre (Free Flow)

7" Barrel

MR730-250E	Mid-range - 7" body diameter x 30" body length - 2½" in/out - straight through
MSB730-250	Flowtech - 7" body diameter x 30" body length - 2½" in/out - baffled
MR730-300E	Mid-range - 7" body diameter x 30" body length - 3" in/out - straight through
MSB730-300	Flowtech - 7" body diameter x 30" body length - 3" in/out - baffled
MR730-350E	Mid-range - 7" body diameter x 30" body length - 3½" in/out - straight through
MSB740-300	Flowtech - 7" body diameter x 40" body length - 3" in/out - baffled - Ford Cargo
MSB740-400	Flowtech - 7" body diameter x 40" body length - 4" in/out - baffled
M740-400	Flowtech - 7" body diameter x 40" body length - 4" in/out - straight through
M744-500	Flowtech - 7" body diameter x 44" body length - 5" in/out - straight through



Mufflers - Centre-Centre (Free Flow)

MB820-225	Flowtech - 8" body diameter x 20" body length - 2¼" in/out - baffled
MB820-238F	Flowtech - 8" body diameter x 20" body length - 2 bolt flange in / 60mm out - baffled
MB820-250	Flowtech - 8" body diameter x 20" body length - 2½" in/out - baffled
MB820-275	Flowtech - 8" body diameter x 20" body length - 2¾" in/out - baffled
MB820-275F	Flowtech - 8" body diameter x 20" body length - 4 bolt flange in / 70mm out - baffled
MB820-300	Flowtech - 8" body diameter x 20" body length - 3" in/out - baffled
MB820-300F	Flowtech - 8" body diameter x 20" body length - 4 bolt flange in / 3" out - baffled
MB822-300H	Flowtech - 8" body diameter x 22" body length - 3" in / 80mm out - baffled
MB824-2F1	Flowtech - 8" body diameter x 24" body length - 2 bolt flange - baffled - suits Isuzu
MB824-2F60	Flowtech - 8" body diameter x 24" body length - 2 bolt flange in / 60mm out - baffled - suit Isuzu
MB824-225	Flowtech - 8" body diameter x 24" body length - 2¼" in/out - baffled
MB824-238	Flowtech - 8" body diameter x 24" body length - 60mm in/out - baffled
MB824-2383	Flowtech - 8" body diameter x 24" body length - 60mm in / 3" out - baffled
MB824-250	Flowtech - 8" body diameter x 24" body length - 2½" in/out - baffled
M824-250	Flowtech - 8" body diameter x 24" body length - 2½" in/out - straight through
MB824-275	Flowtech - 8" body diameter x 24" body length - 2¾" in/out - baffled - suits Hino
MB824-300	Flowtech - 8" body diameter x 24" body length - 3" in/out - baffled
M824-300	Flowtech - 8" body diameter x 24" body length - 3" in/out - straight through
MSB830-250	Flowtech - 8" body diameter x 30" body length - 2½" in/out - baffled
MSB830-300	Flowtech - 8" body diameter x 30" body length - 3" in/out - baffled
MSB830-350	Flowtech - 8" body diameter x 30" body length - 3½" in/out - baffled
M830-400	Flowtech - 8" body diameter x 30" body length - 4" in/out - straight through
MSB830-400	Flowtech - 8" body diameter x 30" body length - 4" in/out - baffled
M832-300	Flowtech - 8" body diameter x 32" body length - 3" in/out - straight through
MSB834-500	Flowtech - 8" body diameter x 34" body length - 5" in/out - baffled
M8534-400	Mid-range - 8½" body diameter x 34" body length - 4" in/out - straight through
MSB8534-400	Flowtech - 8½" body diameter x 34" body length - 4" in/out - baffled
MSB836-300	Flowtech - 8" body diameter x 36" body length - 3" in/out - baffled

CHROMEND SUPPLY CO. – TRUCK CATALOGUE 2007

Mufflers - Centre-Centre (Free Flow)

8" Barrel

MSB836-350	Flowtech - 8" body diameter x 36" body length - 3½" in/out - baffled
M836-400	Flowtech - 8" body diameter x 36" body length - 4" in/out - straight through
MSB836-400	Flowtech - 8" body diameter x 36" body length - 4" in/out - baffled
M836-500	Flowtech - 8" body diameter x 36" body length - 5" in/out - straight through
M838-350	Flowtech - 8" body diameter x 38" body length - 3½" in/out - straight through
MSB840-300	Flowtech - 8" body diameter x 40" body length - 3" in/out - baffled
MSB840-350	Flowtech - 8" body diameter x 40" body length - 3½" in/out - baffled
MSB840-304	Flowtech - 8" body diameter x 40" body length - 3" in / 4" out - baffled
MSB840-400	Flowtech - 8" body diameter x 40" body length - 4" in/out - baffled
M844-500	Flowtech - 8" body diameter x 44" body length - 5" in/out - straight through
MSB844-500	Flowtech - 8" body diameter x 44" body length - 5" in/out - baffled

Mufflers - Centre-Centre (Free Flow)

9" Barrel

R912-400	Flowtech - 9" body diameter x 12" body length - 4" in/out - straight through
R912-500E	Mid-range - 9" body diameter x 12" body length - 5" in/out - straight through
R912-500	Flowtech - 9" body diameter x 12" body length - 5" in/out - straight through
M920-400	Flowtech - 9" body diameter x 20" body length - 4" in/out - straight through
MSB920-400	Flowtech - 9" body diameter x 20" body length - 4" in/out - baffled
M920-500	Flowtech - 9" body diameter x 20" body length - 5" in/out - straight through
MB922-318	Flowtech - 9" body diameter x 22" body length - 80mm in/out - baffled
MB923-8085	Flowtech - 9" body diameter x 23" body length - 80mm / 85mm OD out - baffled - suits Mitsubishi
MSB924-500	Flowtech - 9" body diameter x 24" body length - 5" in/out - baffled
MSB926-300F	Flowtech - 9" body diameter x 26" body length - 4 bolt flange in / 3" out - baffled - suits UD
M926-400	Flowtech - 9" body diameter x 26" body length - 4" in/out - straight through
M930-500	Flowtech - 9" body diameter x 30" body length - 5" in/out - straight through
MSB933-500	Flowtech - 9" body diameter x 33" body length - 5" in/out - baffled
M936-500	Flowtech - 9" body diameter x 36" body length - 5" in/out - straight through
MSB939-485	Flowtech - 9" body diameter x 39" body length - 4" in / 85mm out - baffled - suits Mitsubishi
MSB940-400	Flowtech - 9" body diameter x 40" body length - 4" in/out - baffled - suits Mercedes
MSB940-405	Flowtech - 9" body diameter x 40" body length - 4" in / 5" out - baffled - suits Mercedes
M944-350	Flowtech - 9" body diameter x 44" body length - 3½" in/out - straight through
MB944-350	Mid-range - 9" body diameter x 44" body length - 3½" in/out - baffled
M944-400	Flowtech - 9" body diameter x 44" body length - 4" in/out - straight through
M944-400N	Mid-range - 9" body diameter x 44" body length - 4" in/out - straight through
M944-400E	Mid-range - 9" body diameter x 44" body length - 4" in/out - semi baffled
MB944-400	Mid-range - 9" body diameter x 44" body length - 4" in/out - baffled
MSB944-400	Flowtech - 9" body diameter x 44" body length - 4" in/out - baffled
MB944-405	Mid-range - 9" body diameter x 44" body length - 4" in / 5" out - baffled

CHROMEND SUPPLY CO. – TRUCK CATALOGUE 2007

Mufflers - Centre-Centre (Free Flow)

9" Barrel	
M944-500N	Mid-range - 9" body diameter x 44" body length - 5" in/out - straight through
MS944-500	Mid-range - 9" body diameter x 44" body length - 5" in/out - straight through
M944-500E	Mid-range - 9" body diameter x 44" body length - 5" in/out - semi baffled
MB944-500	Mid-range - 9" body diameter x 44" body length - 5" in/out - baffled
MSB944-500	Flowtech - 9" body diameter x 44" body length - 5" in/out - baffled
M944-600	Flowtech - 9" body diameter x 44" body length - 6" in/out - straight through

Mufflers - Centre-Centre (Free Flow)

10" Barrel	
MB1023-318	Flowtech - 10" body diameter x 23" body length - 80mm in/out - baffled - suits Isuzu
MB1024-300	Flowtech - 10" body diameter x 24" body length - 3" in/out - baffled
MSB1024-400	Flowtech - 10" body diameter x 24" body length - 4" in/out - baffled
MSB1024-500	Flowtech - 10" body diameter x 24" body length - 5" in/out - baffled
MB1027-300F	Flowtech - 10" body diameter x 27" body length - 4 bolt flange in / 3" out - baffled
MSB1030-500	Flowtech - 10" body diameter x 30" body length - 5" in/out - baffled
MSB1036-500	Flowtech - 10" body diameter x 36" body length - 5" in/out - baffled
MSB1039-335F	Flowtech - 10" body dia. x 39" body lgth - 4 bolt flange 3" in / 3½" out - baffled - suits Isuzu
M1044-400	Flowtech - 10" body diameter x 44" body length - 4" in/out - straight through
MSB1044-400	Flowtech - 10" body diameter x 44" body length - 4" in/out - baffled
MB1044-400	Mid-range - 10" body diameter x 44" body length - 4" in/out - baffled
M1044-450	Flowtech - 10" body diameter x 44" body length - 4½" in/out - straight through
VOLVO450	Mid-range - 10" body diameter x 44" body length - lipped flange in / 4½" out - baffled
VOLVO500	Mid-range - 10" body diameter x 44" body length - lipped flange in / 5" out - baffled
M1044-500	Flowtech - 10" body diameter x 44" body length - 5" in/out - straight through - sports
M1044-500E	Mid-range - 10" body diameter x 44" body length - 5" in/out - cone baffle
M1044-600	Flowtech - 10" body diameter x 44" body length - 6" in/out - straight through - sports
MQB1044-500	Flowtech - 10" body diameter x 44" body length - 5" in/out - quieter cone baffle
MSB1044-500	Flowtech - 10" body diameter x 44" body length - 5" in/out - baffled
MSB1044-506	Flowtech - 10" body diameter x 44" body length - 5" in / 6" out - baffled
MSB1044-600	Flowtech - 10" body diameter x 44" body length - 6" in/out - baffled
M1050-438	Flowtech - 10" body diameter x 50" body length - 110mm in / 110mm out - straight through
M1050-450	Flowtech - 10" body diameter x 50" body length - 4½" in/out - straight through
M1050-500	Flowtech - 10" body diameter x 50" body length - 5" in/out - straight through
MSB1055-500	Flowtech - 10" body diameter x 55" body length - 5" in/out - baffled

11" Barrel

MSB1128-300	Flowtech - 11" body diameter x 28" body length - 3" in/out - baffled
MSB1128-350	Flowtech - 11" body diameter x 28" body length - 3½" in/out - baffled
MSB1144-600	Flowtech - 11" body diameter x 44" body length - 6" in/out - baffled

CHROMEND SUPPLY CO. – TRUCK CATALOGUE 2007

Mufflers - Centre-Centre (Free Flow)

12" Barrel

MS1236-438	Flowtech - 12" body diameter x 36" body length - 110mm in/out - straight through - Scania Bus
-------------------	--

Heavy Duty Mufflers - Offset-Offset - Round

MOO624-200H	Flowtech - 6" body diameter x 24" body length - 2" in/out - baffled
MOO624-225H	Flowtech - 6" body diameter x 24" body length - 2¼" in/out - baffled
MOO624-250H	Flowtech - 6" body diameter x 24" body length - 2½" in/out - baffled
MOO628-200	Flowtech - 6" body diameter x 28" body length - 2" in/out - baffled
MOO717-200F	Flowtech - 7" body diameter x 17" body length - 2" in/out - Mitsubishi baffled
MOO717-225FT	Flowtech - 7" body diameter x 17" body length - 3 bolt flange both ends - 2¼" in/out - Mitsubishi Turbo
MOO720-225M	Flowtech - 7" body diameter x 20" body length - 2¼" in/out - straight through
MOO720-250M	Flowtech - 7" body diameter x 20" body length - 2½" in/out - straight through
MOO720-250TR	Flowtech - 7" body diameter x 20" body length - 2½" in/out - Triflow
MOO720-300M	Flowtech - 7" body diameter x 20" body length - 3" in/out - straight through
MOO724-250	Flowtech - 7" body diameter x 24" body length - 2½" in/out - baffled
MOO727-200	Mid-range - 7" body diameter x 27" body length - 2" in/out - baffled
MOO727-5363	Flowtech - 7" body diameter x 27" body length - 53mm in / 63mm out - baffled
MOO819-250F	Flowtech - 8" body diameter x 19" body length - 2 bolt flange both ends - 2½" in/out - baffled - Isuzu
MOO824-250	Flowtech - 8" body diameter x 24" body length - 2½" in/out - baffled
MOO824-300	Flowtech - 8" body diameter x 24" body length - 3" in/out - baffled
MOO8528-300	Mid-range - 8½" body diameter x 28" body length - 3" in/out - baffled
MOO8531-300	Mid-range - 8½" body diameter x 31" body length - 3" in/out - baffled
MOO1028-400	Flowtech - 10" body diameter x 28" body length - 4" in/out - baffled
MOO1036-400	Flowtech - 10" body diameter x 36" body length - 4" in/out - baffled

Heavy Duty Mufflers (Offset-Offset / Offset-Centre & Centre-Centre) - Oval

MCO5929-200	Mid-range - 5"x9" body size x 29" body length - 2" in/out - baffled - centre/offset
MCO9514-350	Flowtech - 9"x5" body size x 14" body length - 3½" in/out - Megaflow - centre/offset
MCO9516-350	Flowtech - 9"x5" body size x 16" body length - 3½" in/out - Megaflow - centre/offset
MCO9514-400	Flowtech - 9"x5" body size x 14" body length - 4" in/out - Megaflow - centre/offset
MCO9516-400	Flowtech - 9"x5" body size x 16" body length - 4" in/out - Megaflow - centre/offset
MB10430-225	Flowtech - 10" x 4" body size x 30" body length - 2¼" in/out - baffled - centre/centre
MOO7828-218	Mid-range - 7"x8" body size x 28" body length - 55mm in/out - baffled - offset/offset
MOO7828-225	Mid-range - 7"x8" body size x 28" body length - 57mm in/out - baffled - offset/offset
MOO81126-300H	Flowtech - 8"x11" body size x 26" body length - 3" in/out - baffled - offset/offset
MOO81126-350	Mid-range - 8"x11" body size x 26" body length - 3½" in/out - baffled - offset/offset
MOO81127-400	Mid-range - 8"x11" body size x 27" body length - 4" in/out - baffled - offset/offset
MOO101526-400	Mid-range - 10"x15" body size x 26" body length - 4" in/out - baffled - offset/offset
MOO101526-500	Mid-range - 10"x15" body size x 26" body length - 5" in/out - baffled - offset/offset
MOO101536-500	Mid-range - 10"x15" body size x 36" body length - 5" in/out - baffled - offset/offset
MOO101532-600	Mid-range - 10"x15" body size x 32" body length - 6" in/out - baffled - offset/offset
MSB11831-2753H	Flowtech - 11"x8" body size x 31" body length - 2¾" in / 3 bolt flanged 3" out - centre/centre

CHROMEND SUPPLY CO. – TRUCK CATALOGUE 2007

Heavy Duty Mufflers (In & Out Same End)		
MSE824-200	Flowtech - 8" body diameter x 24" body length - 2" in/out same end - baffled	
MSE824-250E	Mid-range - 8" body diameter x 24" body length - 2½" in/out same end - baffled	
MSE824-250	Flowtech - 8" body diameter x 24" body length - 2½" in/out same end - baffled	
MSE8522-275	Flowtech - 8½" body diameter x 22" body length - 2¾" in/out same end - baffled	
MSE8522-300	Flowtech - 8½" body diameter x 22" body length - 3" in/out same end - baffled	
MSE8526-275	Flowtech - 8½" body diameter x 26" body length - 2¾" in/out same end - baffled	
MSE924-2503	Mid-range - 9" body diameter x 24" body length - 2½" in / 3" out same end - baffled	
MSE924-300E	Mid-range - 9" body diameter x 24" body length - 3" in/out same end - baffled	
MSE1026-300	Flowtech - 10" body diameter x 26" body length - 3" in/out same end - baffled	
MSE101526-400E	Mid-range - 10"x15" body diameter x 26" body length - 4" in/out same end - baffled	
MSE101526-500E	Mid-range - 10"x15" body diameter x 26" body length - 5" in/out same end - baffled	
MSE101536-500E	Mid-range - 10"x 15" body diameter x 36" body length - 5" in/out same end - baffled	
MSE1026-400	Flowtech - 10" body diameter x 26" body length - 4" in/out same end - baffled	
MSE1126-318	Flowtech - 11" body diameter x 26" body length - 80mm in/out same end - baffled	
MSE1126-318H	Flowtech - 11" body diameter x 26" body length - 80mm ID in / 80mm OD out same end - baffled	
MSE1128-350	Flowtech - 11" body diameter x 28" body length - 3½" in/out same end - baffled	
MSE11831-2753	Flowtech - 11"x 8" body diameter x 31" body length - 2¾" in / 3" out same end - baffled	
MSE11831-2753F	Flowtech - 11"x 8" body dia. x 31" body L - 3 bolt flange - 2¾" in / 3" out same end - baffled	
MSE11833-318350	Flowtech - 11"x 8" body diameter x 33" body length - 80mm in / 90mm out same end - baffled	
MSE11843-3184	Flowtech - 11"x 8" body diameter x 34" body length - 80mm in / 102mm out same end - baffled	
MSE121425-318	Flowtech - 12"x 14" body diameter x 25" body length - 80mm in/out same end - baffled	
MSE1231-350F	Mid-range - 12" body diameter x 31" body length - 4 bolt flange in/out - suit Isuzu	
Heavy Duty Mufflers (Twin In - Single Out Same End)		
MSETW1140-335	Flowtech - 11" body diameter x 40" body length - 2x3" in / 1x3½" OD out same end - baffled	
MSETW1245-335	Flowtech - 12" body diameter x 45" body length - 2x3" in / 1x3½" OD out same end - baffled	
Heavy Duty Mufflers (Dual Inlet - Single Outlet)		
MTS824-2253	Flowtech - 8" body diameter x 24" body length - 2x2¼" in / 1x3" out - baffled	
MTS824-2253SS	Flowtech - 8" body diameter x 24" body length - 2x2¼" in / 1x3" out - baffled - Stainless Steel	
MTS830-2253	Flowtech - 8" body diameter x 30" body length - 2x2¼" in / 1x3" out - baffled	
MTS830-2253SS	Flowtech - 8" body diameter x 30" body length - 2x2¼" in / 1x3" out - baffled - Stainless Steel	
MTS830-2503	Flowtech - 8" body diameter x 30" body length - 2x2½" in / 1x3" out - baffled	
MTS924-2253	Flowtech - 9" body diameter x 24" body length - 2x2¼" in / 1x3" out - baffled	
MTS936-304	Flowtech - 9" body diameter x 36" body length - 2x3" in / 1x4" out - baffled	

CHROMEND SUPPLY CO. – TRUCK CATALOGUE 2007

Heavy Duty Mufflers (End Inlet - Side Outlet)

MSI-618-200	Mid-range - 6" body diameter OD x 18" body length - 2" in/out - baffled
MSI-6520-250	Mid-range - 6½" body diameter OD x 20" body length - 2½" in/out - baffled
MSI-8527-300	Mid-range - 8½" body diameter OD x 27" body length - 3" in/out - baffled
MSI-81126-350	Mid-range - 8"x11" body diameter OD x 26" body length - 3½" in/out
MSI-101536-500	Mid-range - 10"x15" body diameter OD x 36" body length - 5" in/out - baffled

Heavy Duty Mufflers (End Inlet - Side Outlet)

MSO81128-354	Flowtech - 8"x11" body diameter OD x 28" body length - 3½" in / 4" out
MSO1028-400	Flowtech - 10" body diameter OD x 28" body length - 4" in/out - baffled
MSO1036-400	Flowtech - 10" body diameter OD x 36" body length - 4" in/out - baffled
MSO1044-500	Flowtech - 10" body diameter OD x 44" body length - 5" in/out - baffled
MSO1130-400	Flowtech - 11" body diameter OD x 30" body length - 4" in/out - baffled

Heavy Duty Mufflers (End Inlet - Side Outlet - Outlet Near Inlet End)

MSO1028-400I	Midrange 10" body diameter OD x 28" body length - 4" in/out
MSO101536-400	Midrange 10"x15" body diameter OD x 36" body length - 4" in/out - suits Ford LNT 8000
MSO101536-500	Flowtech 10"x15" body diameter OD x 36" body length - 5" in/out - baffled
MSOC1136-400FR	Flowtech 11" body diameter OD x 36" body length - 4" in/out - suits Freightliner FL80
MSO1136-400	Flowtech 11" body diameter OD x 36" body length - 4" in/out - baffled
MSO1136-500	Flowtech 11" body diameter OD x 36" body length - 5" in/out - baffled
MSO1142-405ST	Flowtech 11" body diameter OD x 42" body length - 4" in / 5" out - suits Sterling C12
MSO1148-500FL	Flowtech 11" body diameter OD x 48" body length - 5" in/out - suits Ford LTS 9000
MSO1253-500ST	Flowtech 12" body diameter OD x 53" body length - 5" in/out - suits Sterling HN80

Cup Mufflers - Pepper Pot Style

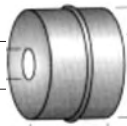
04790M	Inlet 1" NPT - 3½" body diameter - 3½" body length	
48111U	Inlet 1" NPT - 4" body diameter - 3½" body length	
48113U	Inlet 1¼" NPT - 4" body diameter - 3½" body length	



Aspirator Pipes

ASP275	2¾" inlet x 16" long - 1¼" fitting	
ASP300	3" inlet x 16" long - 1¼" fitting	
ASP350	3½" inlet x 16" long - 1¼" fitting	
ASP400	4" inlet x 16" long - 1½" fitting	
ASP500	5" inlet x 16" long - 1½" fitting	

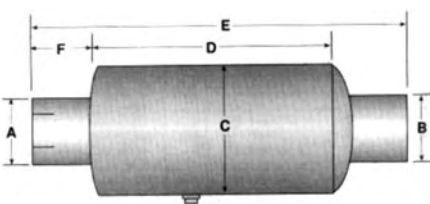
Spark Arrestor Only - These only comply to AS1019-1985 when fitted to a Turbo Engine

SA67-200	6" body diameter x 6½" body length - 2" in/out	
SA69-250	6" body diameter x 9" body length - 2½" in/out	
SA711-300	7" body diameter x 11" body length - 3" in/out	
SA712-350	7" body diameter x 12" body length - 3½" in/out	
SA915-400	9" body diameter x 15" body length - 4" in/out	
SA916-500	9" body diameter x 16" body length - 5" in/out	
SA1222-600	12" body diameter x 22" body length - 6" in/out	

CHROMEND SUPPLY CO. – TRUCK CATALOGUE 2007

Cyclonic Type Spark Arrestors		
Curved Outlet Already Attached		
SPA50	6" body diameter x 14" body length - 2" in/out	
SPA57	6" body diameter x 14" body length - 2¼" in/out	
SPA63	7" body diameter x 14" body length - 2½" in/out	
SPA76	7" body diameter x 16" body length - 3" in/out	
Spigots Only - Outlet Extra		
SPA90	9" body diameter x 20" body length - 43" overall length - 3½" in/out - curved outlet	
SPA102	9" body diameter x 21" body length - 43" overall length - 4" in/out - curved outlet	
SPA127	10" body diameter x 21" body length - 43" overall length - 5" in/out - curved outlet	
Curved Outlet		
CPSA35024P	Curved & Deflected Aluminised Stack 3½" x 24" (600mm) Long - Plain Inlet / Curved Outlet	
CPSA40024P	Curved & Deflected Aluminised Stack 4" x 24" (600mm) Long - Plain Inlet - Curved Outlet	
CPSA50024P	Curved & Deflected Aluminised Stack 5" x 24" (600mm) Long - Plain Inlet - Curved Outlet	
Screen Type Spark Arrestors - Australian Approved		
SAA4138	4" body diameter x 220mm body length - 38mm inlet x 51mm outlet	
SAA4145	4" body diameter x 220mm body length - 45mm inlet x 51mm outlet	
SAA4151	4" body diameter x 220mm body length - 51mm inlet x 51mm outlet	
SAA4157	4" body diameter x 220mm body length - 57mm inlet x 51mm outlet	
SAA4163	4" body diameter x 220mm body length - 63mm inlet x 51mm outlet	
SAA5151	5" body diameter x 300mm body length - 51mm inlet x 76mm outlet	
SAA5157	5" body diameter x 300mm body length - 57mm inlet x 76mm outlet	
SAA5163	5" body diameter x 300mm body length - 63mm inlet x 76mm outlet	
SAA5176	5" body diameter x 300mm body length - 76mm inlet x 76mm outlet	
Spark Arrester Mufflers (Screen Type)		
SAMA4145	4" body diameter x 773mm overall length - 45mm inlet x 51mm curved outlet	
SAMA4151	4" body diameter x 773mm overall length - 51mm inlet x 51mm curved outlet	
SAMA5157	5" body diameter x 773mm overall length - 57mm inlet x 76mm curved outlet	
SAMA5163	5" body diameter x 773mm overall length - 63mm inlet x 76mm curved outlet	
SAMA5176	5" body diameter x 773mm overall length - 76mm inlet x 76mm curved outlet	
Bus Mufflers		
MB722-23856	7" body diameter x 22" body length - 60mm inlet / 56mm outlet - suits Hino	
MB822-300H	8" body diameter x 22" body length - 3" in/out - suits Hino	
MOO101230-400M	10"x12" Oval x 30" body length - 4" in/out - suits MAN	
MSO1125-300BR	11" body diameter x 25" body length - 3" side in/out - suits Mercedes 0305-307	
MSO1227-27540	12" body diameter x 27" body length - 2¾" in / 4" out - suits Mercedes 0405 Bus	
MSOI1227-27580	12" body diameter x 27" body length - 2¾" in / 80mm side out - suits Mercedes 0405	
M1236-438	12" body diameter x 36" body length - 110mm in/out - suits Scania	
MTW181029-275	18"x10" Oval x 29" body length - 2¾" in/out - suits Mercedes 0303 NON-Turbo	
MTW181029-3350	18"x10" Oval x 29" body length - 2¾" in/out - suits Mercedes 0303 TURBO	

CHROMEND SUPPLY CO. – TRUCK CATALOGUE 2007

Tractor Spark Arrestor Mufflers

HTM618-200	6" (152mm) body diameter x 18" (457mm) body length - 37" Overall length - 2" inlet ID (51mm)	
HTM618-225	6" (152mm) body diameter x 18" (457mm) body length - 37" Overall length - 2¼" inlet ID (57mm)	
HTM618-250	6" (152mm) body diameter x 18" (457mm) body length - 37" Overall length - 2½" inlet ID (63mm)	
HTM618-275	6" (152mm) body diameter x 18" (457mm) body length - 37" Overall length - 2¾" inlet ID (70mm)	
HTM618-300	6" (152mm) body diameter x 18" (457mm) body length - 37" Overall length - 3" inlet ID (76mm)	

Universal Heavy Casing Tractor Mufflers

HTM178	6" (152mm) body dia. x 12" (300mm) body L - 28" OAL - 1⅞" inlet ID (44mm) / 2" outlet OD (51mm)
HTM200	6" (152mm) body dia. x 12" (300mm) body L - 28" OAL - 2" inlet ID (51mm) / 2" outlet OD (51mm)
HTM218	6" (152mm) body dia. x 12" (300mm) body L - 28" OAL - 2⅞" inlet ID (54mm) / 2" outlet OD (51mm)
HTM225	6" (152mm) body dia. x 12" (300mm) body L - 28" OAL - 2¼" inlet ID (57mm) / 2¼" outlet OD (57mm)
HTM250	6" (152mm) body dia. x 12" (300mm) body L - 28" OAL - 2½" inlet ID (63mm) / 2½" outlet OD (63mm)
HTM275	6" (152mm) body dia. x 12" (300mm) body L - 28" OAL - 2¾" inlet ID (70mm) / 2½" outlet OD (63mm)
HTM300	6" (152mm) body dia. x 12" (300mm) body L - 28" OAL - 3" inlet ID (76mm) / 3" outlet OD (76mm)

Universal Heavy Casing Tractor Mufflers - * These mufflers require outlet stacks

HTM350*	8" (203mm) body dia. x 15" (380mm) body L - 27" OAL - 3½" inlet ID (89mm) / 3½" outlet ID (89mm)
HTM400*	8" (203mm) body dia. x 15" (380mm) body L - 27" OAL - 4" inlet ID (102mm) / 4" outlet ID (102mm)
HTM500*	8" (203mm) body dia. x 15" (380mm) body L - 27" OAL - 5" inlet ID (127mm) / 5" outlet ID (127mm)

Universal Baffled Hotdog Tractor Mufflers

MASSEY1	3½" (89mm) body diameter - hotdog tractor muffler - 2" inlet ID - curved outlet
----------------	--

Bobcat Mufflers - Suits Melroe, Clark & Mustang

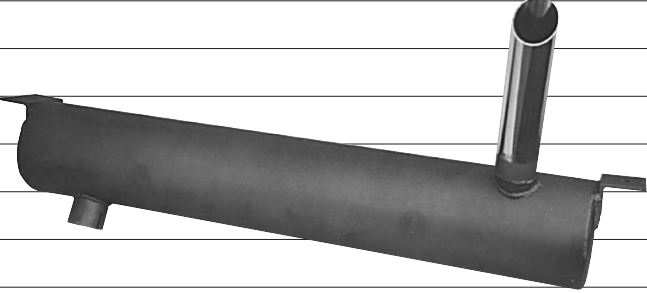
17410T	Suits 642, 543, 742, 743 models	
17753T	Suits 753, 763 models	
17773T	Suits 773 model	
17840T	Suits Case 1840	
17853T	Suits 843, 853 models	
17863T	Suits 863 model Turbo	
17940T	Suits Mustang 940 model	
18853H	Suits 853H model	