

Mitsubishi Triton 2006-2009 ML 3.2L DI-D 4M41T Eng. Common Rail

OS-PROV-22



MANN Provent 200 IV Oil Catch Can Kit Install Guide

CAUTION: ** Ensure the engine is OFF & COOL before installation ! **

STEP 1: Identify Install Area.

STEP 2: Swivel Provent Inlet to the correct position. Attach the Drain Hose to the base of the Provent. Secure with clamp. Attach the ball valve Tap, secure with supplied clamp.

**** Ensure Tap is CLOSED ****

STEP 3: Fit the Provent 200 to the supplied Bracket

STEP 4: Identify and release the factory fittings. Position and fit the Provent Bracket, return fittings and tighten.



STEP 1:



STEP 2:



STEP 3:



STEP 4:

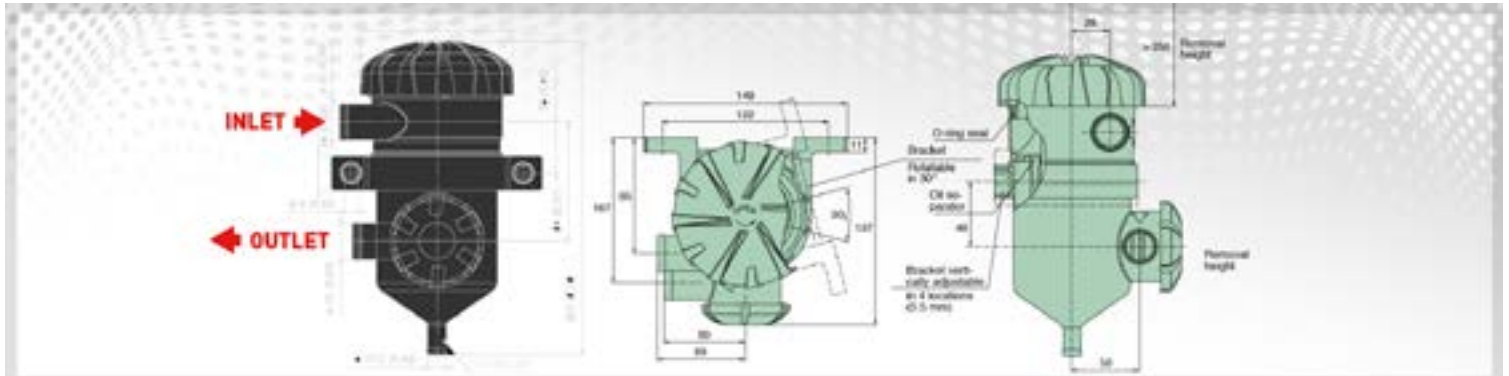

WARNING: Engine damage will occur if incorrectly connected. Please follow Installation Guide

- STEP 7:** Mount the Bracket to the vehicle, running the clear Drain Hose down between the inner guard and chassis rail,
- STEP 8:** Remove the Breather Hose from the top of the Crankcase which runs to the Air Inlet.
- STEP 9:** Attach the Short Straight Hose to Provent's Lower Outlet, join the other end to the Air Inlet. Secure all hoses with clamps.
- STEP 10:** Attach the Long Molded Bent Hose to the Provent Top Inlet, Attach the 16mm end to the Crank Case Outlet . Secure with supplied clamps.
- STEP 11:** Re-fit the Plastic Engine Cover.



STEP 7:

[View Install Slide Presentation: SCAN QR-CODE \(page.1\) >](#)



STEP 8:



STEP 9:



STEP 10: